

The Americans with Disabilities Act Guide

For Lodging Owners & Operators

Written by
Minh N. Vu, Esq.

Contributors

Karen Stephenson, Esq., Kristina Launey, Esq., Laura Robinson, Esq., Seyfarth Shaw LLP

Developed by



Funded by





About the author:

Minh N. Vu is a partner in the Washington D.C. office of Seyfarth Shaw LLP and the head of the ADA Title III Team at the firm. Since 2006, she has served as the American Hotel & Lodging Association's ADA Title III counsel and represented the lodging industry in the rulemaking that produced the 2010 revised ADA Title III regulations as well as other rulemakings relating to accessible websites, equipment, and furniture.

Ms. Vu oversaw the enforcement of the ADA as Counselor to the Assistant Attorney General for Civil Rights at the U.S. Department of Justice (DOJ) before returning to private practice. Her practice focuses exclusively on federal and state laws prohibiting discrimination on the basis of disability, including but not limited to, the ADA, the Fair Housing Act, California Unruh Act, and Disabled Persons Act. Ms. Vu is the trusted advisor to many of the country's top lodging and gaming companies, financial institutions, retailers, and equipment manufacturers who turn to her for compliance advice, training, and representation in enforcement lawsuits and government investigations.

Ms. Vu has successfully defended these public accommodations in some of the most significant nationwide lawsuits and enforcement actions brought by private plaintiffs and the Department of Justice.

**THE AMERICANS WITH DISABILITIES ACT (ADA) GUIDE
for Lodging Owners and Operators**

A publication of
The American Hotel & Lodging Association
1201 New York Avenue, NW
Washington, DC 20005

Written by
Minh N. Vu, Esq.

Other Contributors
Karen Stephenson, Esq.
Kristina Launey, Esq.
Laura Robinson, Esq.
Seyfarth Shaw LLP
975 F Street, NW
Washington, DC 20004

Copyright 2012
The American Hotel & Lodging Association
Washington, DC
&
Seyfarth Shaw LLP
Washington, DC

(Updated September 1, 2012)

Disclaimer: This document provides general information to promote voluntary compliance with the Americans with Disabilities Act (ADA). The information provided is not legal, architectural, engineering, or other professional advice. Readers should refer specific questions to their attorneys, architects, and/or engineers.

TABLE OF CONTENTS

| | | |
|-------|---|----|
| I. | INTRODUCTION | 1 |
| II. | STATUTORY AND REGULATORY OVERVIEW..... | 2 |
| III. | DEFINITION OF “PLACE OF LODGING”: GOING BEYOND HOTELS, MOTELS AND INNS..... | 3 |
| IV. | THE OBLIGATION TO PROVIDE ACCESSIBLE FACILITIES | 4 |
| A. | The Standards for Barrier Removal, Alterations, and New Construction | 5 |
| 1. | Readily Achievable Barrier Removal for Pre-ADA Facilities | 5 |
| 2. | Alterations to Lodging Facilities after January 26, 1992..... | 7 |
| 3. | New Construction | 8 |
| B. | Which Standard Applies: The 1991 Standards or the 2010 Standards? | 8 |
| C. | Safe Harbor for Certain Existing Elements and Spaces..... | 9 |
| D. | New Requirements for Recreational Facilities | 9 |
| E. | The 1991 and 2010 Standards for Elements and Spaces Commonly Found in Lodging Facilities | 10 |
| 1. | Concepts Applicable Throughout Lodging Facilities | 10 |
| a. | Construction Tolerances | 10 |
| b. | Conventions | 11 |
| c. | Equivalent Facilitation | 11 |
| d. | Accessible Routes | 11 |
| e. | Protruding Objects | 13 |
| f. | Turning Spaces..... | 14 |
| g. | Doors and Entrances | 15 |
| h. | Access to Operable Parts and Self-Service Items | 19 |
| (i) | Clear Floor Space..... | 19 |
| (ii) | Reach Range | 20 |
| (iii) | Operability | 23 |

TABLE OF CONTENTS

| | | |
|-------|---|----|
| i. | Signage..... | 23 |
| 2. | Accessible Parking..... | 25 |
| 3. | Passenger Loading Zones | 27 |
| 4. | Sales and Service Counters..... | 28 |
| 5. | Public Restrooms | 29 |
| a. | Accessible Sink Requirements..... | 30 |
| b. | Wheelchair Accessible Stalls..... | 32 |
| c. | Ambulatory Accessible Stalls..... | 35 |
| 6. | Accessible Guest rooms..... | 36 |
| a. | Accessible Rooms Overview | 36 |
| b. | Calculating the Number of Required Accessible Rooms | 39 |
| (i) | 1991 Standards..... | 39 |
| (ii) | 2010 Standards..... | 41 |
| c. | Dispersion of Accessible Rooms | 42 |
| d. | Accessible Rooms with Mobility Features | 42 |
| (i) | General Requirements..... | 42 |
| (ii) | Accessible Toilet requirements..... | 43 |
| (iii) | Accessible Bathing Fixtures | 45 |
| e. | Accessible Rooms with Communications Features for the Deaf or Hard of Hearing | 49 |
| f. | Accessible Rooms with Mobility and Communications Features for the Deaf or Hard of Hearing | 50 |
| 7. | Ice and Vending Machine Areas..... | 51 |
| 8. | Restaurants and Bars..... | 51 |
| a. | Accessible Seating | 51 |
| b. | Self-Service Items..... | 52 |

TABLE OF CONTENTS

| | | |
|-------|---|----|
| 9. | Business Center..... | 53 |
| 10. | Meeting Rooms..... | 53 |
| 11. | Recreational Facilities..... | 54 |
| a. | Fitness Centers..... | 54 |
| b. | Swimming Pools, Spas, and Wading Pools..... | 55 |
| (i) | Pool Lift..... | 56 |
| (ii) | Sloped Entry..... | 57 |
| (iii) | Transfer Wall..... | 59 |
| (iv) | Transfer Systems..... | 60 |
| (v) | Pool Stairs..... | 60 |
| c. | Steam Rooms and Saunas..... | 61 |
| V. | REASONABLE MODIFICATION OF POLICIES, PRACTICES, AND PROCEDURES..... | 61 |
| A. | Common Modifications..... | 61 |
| B. | Reservations and the Proper Assignment of Accessible Rooms..... | 63 |
| C. | Service Animals..... | 64 |
| D. | Power Mobility Devices..... | 66 |
| E. | Emergency Procedures..... | 67 |
| VI. | AUXILIARY AIDS AND SERVICES..... | 68 |
| A. | Effective Communication Requirements..... | 68 |
| 1. | Communicating with Guests Who are Blind or Have Low Vision..... | 69 |
| 2. | Communicating with Guests Who are Deaf or Hard of Hearing..... | 70 |
| 3. | Communicating with Guests Who Have Speech Disabilities..... | 71 |
| B. | Communication Kits and TTYs..... | 72 |
| C. | Closed Captioning of TVs..... | 72 |
| D. | Automated Teller Machines (ATMs)..... | 73 |

TABLE OF CONTENTS

| | | |
|-------|--|----|
| E. | Websites and Self-Service Equipment | 73 |
| VII. | MAINTENANCE OF ACCESSIBLE FEATURES | 73 |
| VIII. | TRANSPORTATION..... | 74 |
| IX. | DISABILITY ETIQUETTE | 75 |
| X. | CALIFORNIA LODGING FACILITIES..... | 76 |
| A. | The Unruh Civil Rights Act and the Disabled Persons Act..... | 76 |
| B. | Differences Between Title 24 and the ADA Standards | 77 |
| XI. | RESOURCES | 80 |

I. INTRODUCTION

More than twenty years have passed since the Americans with Disabilities Act (ADA) became law. Title III of the ADA prohibits discrimination by places of public accommodation against individuals with disabilities.¹ Places of lodging² are places of accommodation that must comply with these non-discrimination requirements.

Lodging owners and operators are well-versed in hospitality. Compliance with the ADA should be viewed as a part of this philosophy. The ADA's non-discrimination requirements are designed to ensure that individuals with disabilities feel welcome and are able to enjoy all of the goods, services, facilities, and amenities that a place of lodging has to offer. The law requires places of lodging to do more than simply refrain from treating individuals with disabilities differently because of their disabilities. The ADA imposes affirmative obligations that in many cases require lodging facilities to commit additional resources to ensure equal access. To that end, a place of lodging must:

- Ensure that facilities are physically accessible to individuals with disabilities;
- Make reasonable modifications to policies, practices, and procedures as necessary to ensure that individuals with disabilities have access to the goods, services, facilities, and amenities that the lodging facility offers;
- Provide auxiliary aids and services as necessary, and at no additional charge, to ensure that individuals with disabilities have access to the goods, services, facilities, and amenities that the lodging facility offers; and
- Maintain a facility's accessible features.

In addition, it is important for lodging facility employees to know how to interact with individuals with disabilities. This guide will address each of these obligations in further detail, and how they typically arise in the lodging context.

The American Hotel & Lodging Association (AH&LA) developed this guide to provide owners and operators of places of lodging with an overview of the law and the recent regulatory changes that impact their facilities and operations. However, owners and operators must keep in mind that the information in this guide is not legal advice, nor should it be used as a design manual. The ADA and its accompanying regulations and accessibility standards are complex. *Therefore, lodging owners and operators must carefully review the statute, regulations, and applicable accessibility standards before taking any action that could impact access to or use of a lodging facility by an individual with a disability.* Additionally, determining what actions are required for ADA compliance almost always requires an analysis of site-specific conditions and

¹ Title III of the ADA is codified at 42 U.S.C. §1218 *et seq.*

² Places of lodging are also referred to in this guide as "lodging facilities."

other facts. Accordingly, owners and operators of lodging facilities must consult with their attorneys and/or ADA consultants when addressing specific compliance questions.

To assist businesses with complying with the ADA, Section 44 of the IRS Code allows a tax credit for eligible small businesses and Section 190 of the IRS Code allows a tax deduction for all businesses. More information about these tax incentives is at:

<http://www.ada.gov/taxincent.htm>

II. STATUTORY AND REGULATORY OVERVIEW

The Department of Justice (DOJ) has responsibility for issuing regulations to implement the ADA's requirements with respect to places of lodging and other "places of public accommodation" and enforcing the law through federal lawsuits. The DOJ also has responsibility for issuing, as part of those regulations, accessible design standards that are consistent with guidelines issued by another federal agency, the United States Access Board (Access Board). In 1991, the DOJ issued the first ADA Title III regulations (1991 Regulations) which consisted of (1) ADA Standards for Accessible Design for places of public accommodation (1991 Standards); and (2) other non-discrimination requirements relating to the physical aspects and operations of places of public accommodation.

In 2010, the DOJ issued new ADA regulations (2010 Regulations) which amend the 1991 Regulations in several key respects. First, the 2010 Regulations adopt a new set of accessible design standards (2010 Standards) that differ from the 1991 Standards in some important ways. Second, the 2010 Regulations revise and/or clarify the rules concerning key operational issues such as service animals, power mobility devices, effective communication, accessible guest room reservations, and event ticketing.³ Third, the 2010 Regulations -- for the first time -- define the term "place of lodging." The text of the 2010 Regulations and the 2010 Standards can be found online at www.ada.gov or in the Code of Federal Regulations at (28 C.F.R. Part 36 (Subpart D)) and (36 C.F.R. Part 1191 (Appendices B and D)).

The 2010 Regulations became effective on March 15, 2011. However, compliance with the requirements for accessible guest room reservations, newly covered recreational facilities (except swimming pools, spas, and wading pools), and Automated Teller Machine (ATM) communications requirements was not required until March 15, 2012. Existing swimming pools, spas, and wading pools must comply with the 2010 Standards by January 31, 2013 if compliance is readily achievable. Additionally, and as explained below, application of the 2010 Standards to newly constructed and altered lodging facilities was not mandatory until March 15, 2012.

A place of lodging owner, operator, lessor, or lessee whose facilities do not comply with the ADA's requirements faces the following risks:

³ Event ticketing is beyond the scope of this guide. However, the requirements may be found at 28 C.F.R. §36.302(f).

- Enforcement actions by the DOJ. The U.S. Attorney General has authority to investigate alleged violations of the ADA and to bring enforcement lawsuits in federal court if compliance disputes cannot be resolved with a settlement agreement or consent decree. These enforcement actions can involve a single lodging facility or an entity's entire portfolio or system. In successful enforcement actions, the United States can obtain injunctive relief (*e.g.*, a court order requiring a facility to make modifications or alterations to enhance accessibility, or to adopt accessibility-related policies), damages for aggrieved persons, and a civil penalty of up to \$55,000 for a first violation and \$110,000 for each subsequent violation. If the United States seeks damages for aggrieved persons in a nationwide enforcement action, the amount can be substantial.
- Federal lawsuits by private plaintiffs. Private plaintiffs can file federal lawsuits to enforce the ADA. These plaintiffs do not need to first follow an administrative process or give notice to the defendant of the violation. In these suits, plaintiffs can obtain injunctive relief and attorneys' fees, but no monetary damages. These lawsuits can be brought by one or more plaintiffs, or as nationwide class actions. Many plaintiffs also allege state law claims in their federal lawsuits because many state laws provide for monetary damages and attorneys' fees. In class actions alleging both ADA and state law violations, the monetary damages can be substantial.

III. DEFINITION OF “PLACE OF LODGING”: GOING BEYOND HOTELS, MOTELS AND INNS

Title III of the ADA applies to “places of public accommodation,” a term that includes a “place of lodging.” The 1991 Regulations did not define “place of lodging,” resulting in some confusion about whether facilities such as timeshares and condos were covered by the rules applicable to places of lodging. The DOJ tried to address that confusion in the 2010 Regulations by defining a “place of lodging” to include:⁴

- (i) An inn, hotel, or motel; or
- (ii) A facility that –
 - (A) Provides guest rooms for sleeping for stays that primarily are short-term in nature (generally 30 days or less) where the occupant does not have the right to return to a specific room or unit after the conclusion of his or her stay; and
 - (B) Provides guest rooms under conditions and with amenities similar to a hotel, motel, or inn, including the following –

⁴ A place of lodging does *not* include an establishment located within a facility that contains no more than five rooms for rent, and is occupied by the proprietor as a residence.

- (1) On- or off-site management and reservations service;
- (2) Rooms available on a walk-up or call-in basis;
- (3) Availability of housekeeping or linen service; and
- (4) Acceptance of reservations for a guest room type without guaranteeing a particular unit or room until check-in, and without a prior lease or security deposit.

In the timeshare world, there are many different types of ownership rights, and a fact-specific analysis of each facility applying these criteria must be conducted by legal counsel to determine if a facility is a place of lodging.

The analysis is equally complicated in facilities where the units or guest rooms are individually owned (*e.g.*, condos, private cottages, homes). The 2010 Regulations contemplate that such individually owned guest rooms or units can be covered as places of lodging when they meet the definition above. Because many facilities consisting of individually owned units are rented to the public for short-term stays and vary in the amenities and terms that they offer, determining whether they, and the common facilities that serve them, are places of lodging will require an individualized analysis of the facts by experienced ADA counsel.

Even in the case where an individually owned unit or guest room is considered a place of lodging, the 2010 Regulations provide the following exceptions:

- Guest rooms in existing facilities that are not owned by the entity that owns, leases, or operates the overall facility, and whose interior physical features are controlled by their individual owners, are not subject to the ADA's requirements to remove barriers to access or to make alterations in compliance with the applicable ADA standards.
- Reservations for individual guest rooms or other units not owned or substantially controlled by the entity that owns, leases, or operates the overall facility do not have to comply with certain reservations requirements, including holding accessible rooms/units for use by individuals who request accessible rooms/units until they are the last of their type to be sold, blocking accessible rooms/units from inventory once reserved, and issuing a guarantee for the reserved room/unit. These exceptions are discussed further in Section V.B, below.

IV. THE OBLIGATION TO PROVIDE ACCESSIBLE FACILITIES

When Congress enacted the ADA in 1990, it recognized that providing accessibility in pre-ADA facilities (*i.e.*, facilities constructed for first occupancy prior to January 26, 1993) would be more challenging than in facilities constructed after the ADA's requirements went into effect. Congress also recognized that owners and operators of pre-ADA facilities would have an opportunity to bring their facilities into compliance when they renovate them. Accordingly, the

ADA mandates different levels of accessibility depending on whether a place of lodging is a pre-ADA facility, a pre-ADA facility altered since January 26, 1992, or a post-ADA facility (*i.e.*, constructed for first occupancy after January 26, 1993).

Owners and operators of lodging facilities must be mindful that the federal ADA standards for accessibility are not necessarily the same as applicable state or local building codes. Thus, approval from the local permitting authorities for a renovation or new construction project does not signify compliance with the ADA.

A. The Standards for Barrier Removal, Alterations, and New Construction

1. Readily Achievable Barrier Removal for Pre-ADA Facilities

A common misconception about the ADA is that lodging facilities constructed prior to the ADA's enactment are "grandfathered" and do not have to comply with the 1991 Standards. In fact, lodging facilities constructed for first occupancy before January 26, 1993, have a continuing obligation to remove architectural barriers to access if it is "readily achievable" to do so. This obligation exists even if no alterations have been made to the lodging facility since January 26, 1992. As discussed in the previous section, guest rooms/units in existing facilities that are not owned by the entity that owns, leases, or operates the overall facility, and whose interior physical features are controlled by their individual owners, are exempt from the barrier removal obligation.

The barrier removal analysis involves a determination of whether (1) an element presents a "barrier" to access by an individual with a disability, and (2) removal of the barrier is "readily achievable." For the first question, the DOJ's approach has generally been to determine whether the element complies with the 1991 Standards. For example, the 1991 Standards require that an accessible door provide 32" of clear width when open at 90 degrees. If a pre-ADA door provides only 28" of clear width, it will be considered a barrier because there will not be enough space for a typical wheelchair to pass through the door. Starting on March 15, 2012, the DOJ will likely look to the 2010 Standards to determine if an element constitutes a "barrier." Elements that already comply with the 1991 Standards are in a "safe harbor" and do not have to comply with the 2010 Standards until they are altered.

The second question is whether removal of the barrier is "readily achievable." The ADA defines "readily achievable" as "easily accomplishable and able to be carried out without much difficulty or expense." (28 C.F.R. Part 36, Subpart A, §36.104.)⁵ The application of this standard

⁵ The full definition of "readily achievable" is as follows: "*Readily achievable* means easily accomplishable and able to be carried out without much difficulty or expense. In determining whether an action is readily achievable, factors to be considered include – (1) The nature and cost of the action needed under this part; (2) The overall financial resources of the site or sites involved in the action; the number of persons employed at the site; the effect on expenses and resources; legitimate safety requirements that are necessary for safe operation, including crime prevention measures; or the impact otherwise of the action upon the operation of the site; (3) The geographic separateness, and the administrative or fiscal relationship of the site or sites

depends on a number of factors, including the nature and cost of the action needed to remove the barrier; the impact of the action on operational issues; legitimate safety requirements; and the facility owner's or operator's (and its parent's) resources. In short, the readily achievable analysis is highly case-specific and difficult to conduct. Owners or operators seeking to claim that an action is not readily achievable should refer specific questions to their attorneys, architects, and/or engineers.

Some examples of barrier removal actions include:

- Installing ramps;
- Making curb cuts in sidewalks;
- Creating designated accessible parking spaces;
- Repositioning shelves;
- Repositioning telephones;
- Adding raised markings on elevator control buttons;
- Installing flashing alarm lights;
- Widening doors;
- Installing offset hinges to widen doorways;
- Rearranging toilet partitions to increase maneuvering space;
- Insulating lavatory pipes under sinks to prevent burns;
- Installing a raised toilet seat;
- Installing a full-length bathroom mirror;
- Repositioning the paper towel dispenser in a bathroom;
- Installing an accessible paper cup dispenser at a non-accessible water fountain;
- Removing high pile, low density carpeting;

in question to any parent corporation or entity; (4) If applicable, the overall financial resources of any parent corporation or entity; the overall size of the parent corporation or entity with respect to the number of its employees; the number, type, and location of its facilities; and (5) If applicable, the type of operation or operations of any parent corporation or entity, including the composition, structure, and functions of the workforce of the parent corporation or entity.”

- Installing accessible door hardware in an accessible guest room;
- Rearranging or removing tables, chairs, and other furniture from an accessible guest room to create more wheelchair maneuvering space;
- Removing a bed frame to lower a bed so that a guest in a wheelchair can transfer onto the bed; and
- Installing grab bars in an accessible guest room bathtub.

This is a non-exclusive list and will vary based on the relevant factors discussed above. The regulations state that the rearrangement of temporary or movable structures such as furniture, equipment, and display racks is not readily achievable to the extent that it results in a significant loss of selling space.

If removing a barrier is not readily achievable, then a lodging facility must try to take some alternative action to ensure that the barrier does not prevent an individual with a disability from enjoying available goods and services. For example, if there is no accessible route to the spa in a pre-ADA lodging facility and it is not readily achievable to create such a route, the lodging facility might arrange to provide spa services in an alternate (accessible) location.

2. Alterations to Lodging Facilities after January 26, 1992

Lodging facilities make changes to their facilities to keep them up-to-date and inviting to guests. These changes can be “alterations” (as defined below) that trigger ADA compliance obligations in two ways:

- First, any alterations made to a lodging facility after January 26, 1992 must comply with the applicable ADA standards “to the maximum extent feasible” (as defined below).
- Second, when alterations are made to a “primary function area” (as defined below) an additional amount of up to 20% of the alterations budget must be spent to make the path of travel to the primary function area, and the telephones, restrooms, and water fountains serving that area, accessible. This obligation is often referred to as the “path of travel” obligation.

An alteration is a change that “affects or could affect the usability of the building or facility or any part thereof.” (36 C.F.R. §36.402). Normal maintenance, reroofing, painting, wallpapering, or changes to mechanical and electrical systems are generally not considered to be covered alterations. However, changes to aspects of mechanical or electrical fixtures that are used by guests (*e.g.*, replacing thermostat controls) would be covered alterations. Similarly, changing a floor covering is a covered alteration because the floor covering could affect whether a wheelchair can easily roll across the floor.

The 1991 Standards contain a rule that if “alterations of single elements, when considered together, amount to an alteration of a room or space in a building or facility, the entire space shall be made accessible.” (1991 Standards Section 4.1.6(c)) This requirement was not retained in the 2010 Standards, suggesting that the obligation to comply with the 2010 Standards only extends to the particular element or space being altered.

Compliance “to the maximum extent feasible” applies when the nature of a facility makes it virtually impossible to fully comply with the applicable ADA standards through a planned alteration. In these circumstances, any altered areas of the facility that can be made accessible must be made accessible. Unlike readily achievable barrier removal, application of this standard does not take into account the facility owner’s or operator’s resources.

To determine if an alteration triggers the “path of travel” obligation, a lodging facility has to determine if the area that is being renovated is a primary function area. The 1991 and 2010 Regulations both define a primary function area as any area where a “major activity takes place for which the facility is intended.” In a lodging facility, areas such as the front/reception desk, guest rooms, meeting rooms, and restaurants and bars likely would be considered primary function areas. By contrast, the DOJ’s ADA Title III Technical Assistance Manual (*See Resources section at the end of this guide.*) states that restrooms, employee lounges or locker rooms, and corridors are not primary function areas.

The 2010 Regulations specifically exempt from the alterations requirements set forth above guest rooms that are not owned or substantially controlled by the entity that owns, leases, or operates the overall facility if the physical features of the guest room’s interior are controlled by their individual owners.

3. New Construction

Facilities constructed for first occupancy after January 26, 1993 must comply with the applicable ADA standards unless compliance is “structurally impracticable.” The DOJ has stated that this defense only applies “in those rare circumstances when the unique characteristics of terrain prevent the incorporation of accessible features.” (28 C.F.R. Part 36, Subpart D, §36.401(c) (1)) Even then, compliance with the applicable ADA standards is required to the extent it is not structurally impracticable.

B. Which Standard Applies: The 1991 Standards or the 2010 Standards?

All barrier removal, alterations, and new construction that took place prior to September 15, 2010 are governed by the 1991 Standards. The question of which standards govern barrier removal, alterations, and new construction taking place on or after September 15, 2010 is complicated. While the rule is discussed below, lodging facility owners and operators should consult their attorneys when determining which standards apply in specific situations.

The date used to determine which standard should be applied is:

- the date of the last application for a building permit or permit extension is certified to be complete by a State, county, or local government; or

- the date the last application for a building permit or permit extension is received by a State, county, or local government, where the government does not certify the completion applications; or
- the start of physical construction or alterations, if no permit is required.

If the date is on or after September 15, 2010, but before March 15, 2012, then the barrier removal/alterations/new construction may comply with either the 1991 Standards or the 2010 Standards. However, DOJ stated in one guidance that each lodging facility must choose one standard and apply it for the entire project.⁶ If the date is on or after March 15, 2012, then the barrier removal/alterations/new construction must comply with the 2010 Standards.

Thus, for example, a new construction project whose permit application was certified to be complete prior to March 15, 2012, could comply with the 1991 Standards even if the construction did not begin until after March 15, 2012.

C. Safe Harbor for Certain Existing Elements and Spaces

If an element or space in an existing lodging facility already complies with the 1991 Standards as of March 15, 2012, it will not have to be modified to comply with the 2010 Standards until it is altered. However, if an element or space in a lodging facility does not comply with the 1991 Standards on March 15, 2012, then the 2010 Standards apply and the lodging facility will be expected to bring those elements or spaces into compliance with the 2010 Standards to the extent required by the applicable requirements for barrier removal, alterations, or new construction as discussed above.

As discussed in Section D below, there is no safe harbor for existing elements that are covered for the first time in the 2010 Standards (*e.g.*, swimming pools and spas, saunas, exercise machines and equipment, and golf facilities). These newly-covered elements must be made to comply with the 2010 Standards to the extent readily achievable.

D. New Requirements for Recreational Facilities

The 2010 Standards contain requirements and standards for a number of recreational facilities for the first time. These include:

- Swimming pools, wading pools, and spas
- Saunas and steam rooms
- Exercise machines and equipment
- Play areas

⁶ This statement appears to conflict with the 2010 Regulations' statement at 28 C.F.R. § 36.211(c) which states: "If the 2010 Standards reduce the technical requirements or the number of required accessible elements below the number required by the 1991 Standards, the technical requirements or the number of accessible elements in a facility subject to this part may be reduced in accordance with the requirements of the 2010 Standards."

- Fishing piers and platforms
- Recreational boating facilities
- Golf facilities
- Amusement rides
- Mini golf facilities
- Shooting facilities
- Team or player seating
- Accessible route to bowling lanes
- Accessible route to court sports facilities

As discussed in the previous section, *there is no safe harbor for these existing recreational facilities*. The 2010 Regulations require lodging facility owners and operators to bring these existing recreational facilities into compliance with the 2010 Standards if it is “readily achievable” to do so. The compliance date is March 15, 2012 for all elements except swimming pools, spas, and wading pools. For these three elements, the DOJ extended the compliance deadline to January 31, 2013. Section IV.E.11 of this guide discusses the 2010 Standards requirements for some of these facilities that are commonly found in lodging facilities. Lodging facility owners and operators will have to evaluate whether their existing recreational facilities comply with the 2010 Standards and, if not, whether it is readily achievable to bring them into compliance. The discussion of “readily achievable” is in Section IV.A.1 of this guide.

E. The 1991 and 2010 Standards for Elements and Spaces Commonly Found in Lodging Facilities

The purpose of this section is not to provide lodging facility owners and operators with an exhaustive checklist to determine their facilities’ compliance with the ADA. Rather, this section identifies the main requirements for elements and spaces that are commonly found in lodging facilities and highlights major differences between the 1991 Standards and the 2010 Standards that apply to those elements and spaces. If the standards have not changed, this guide will incorporate diagrams from the 2010 Standards. Lodging facility owners and operators should carefully discuss with their counsel which standards apply to their facilities, and should review the specific standards before embarking on any new construction or renovation project.

1. Concepts Applicable Throughout Lodging Facilities

a. Construction Tolerances

Both the 1991 Standards and the 2010 Standards recognize the concept of construction tolerances. However, under the 2010 Standards, construction tolerances will only apply to dimensions that are stated in absolute terms. If the standards specify a range of dimensions, the construction tolerance is considered to be reflected in the range.

b. Conventions

Section 104.2 of the 2010 Standards provides that where the required number of accessible elements or facilities is determined by calculating ratios or percentages, and the calculation results in a remainder or fraction (*e.g.*, 5.2), the entity should round up that figure to the next greater whole number (*e.g.*, 6). Conversely, where the required size or dimension of accessible elements or facilities is determined by applying ratios or percentages, rounding down for values less than one-half is permissible.

c. Equivalent Facilitation

Both the 1991 Standards and the 2010 Standards permit the use of alternative designs, products, or technologies other than those prescribed, provided that the alternatives result in substantially equivalent or greater accessibility and usability of the facility. (*See* 1991 Standards Section 2.2; 2010 Standards Section 103.) The purpose of allowing for equivalent facilitation is to encourage flexibility and innovation while still ensuring access to individuals with disabilities.

d. Accessible Routes

Individuals who use wheelchairs and other mobility devices need a route that they can use to reach all parts of a lodging facility where guests are allowed to go. This path is referred to in the 1991 Standards and the 2010 Standards as an “accessible route.” The ADA requires at least one accessible route that connects accessible entrances to all interior areas of a lodging facility that provide amenities and services (*e.g.*, registration, guestrooms, and restaurants). The ADA also requires at least one accessible route that connects accessible parking spaces, accessible passenger loading zones, public streets and sidewalks, and public transportation stops to the accessible facility entrance(s) that they serve.⁷

An accessible route can consist of walks, ramps, curb ramps (sometimes referred to as curb cuts), elevators, and lifts (in pre-ADA facilities). The basic route requirements are as follows:

- 36” (W) min., narrowing to 32” (W) min. at doorways or for distances of 24” or less;
- Running slope (*i.e.*, slope in the direction of travel) no greater than 8.33%;
- If running slope is between 5% and 8.33%, route must comply with ramp requirements (*see* below);
- Running slope (*i.e.* slope in the direction of travel) of 5% or less is a compliant walk;

⁷ If the only means of access between a site arrival point and accessible facility entrance(s) is a vehicular way that does not provide pedestrian access, an accessible pedestrian route is not required.

- Max. cross slope (*i.e.*, slope perpendicular to the direction of travel) of 2%;
- Firm, stable, and slip resistant;
- No cracks or gaps of more than ½”;
- No abrupt changes in level greater than ¼” or ½” with a 1:2 bevel; and
- Carpets or carpet tile must be securely attached with a firm pad or backing, level cut with a pile height of no more than ½”, and exposed edges must be securely fastened.

The foregoing requirements for an accessible route are stated in the 2010 Standards at Sections 206 and 401-404 and are, for the most part, the same as the 1991 Standards.

One element of an accessible route can be a compliant ramp. However, there are very specific requirements for accessible ramps so owners and operators seeking to install a ramp must consult with a qualified architect or ADA consultant to ensure that the ramp meets the requirements. Some of the key requirements are:

- Max. running slope (*i.e.*, slope in the direction of travel) is 8.33%;
- Max. cross slope (*i.e.*, slope perpendicular to the direction of travel) is 2%;
- Max. rise for any ramp run is 30”;
- Ramp runs with a rise greater than 6” must have compliant handrails (2010 Standards Section 505) and edge protection (2010 Standards Fig. 405.9.1);
- Min. clear width of a ramp run (and where handrails are provided, the clear width between handrails) is 36”;
- Ramp run surfaces must be firm, stable, and slip resistant;
- Landings must be provided at the top and bottom of each ramp run. The landings must be level, at least as wide as the ramp they serve, and at least 60” long;
- Ramps with a rise greater than 30” must have an intermediate landing; and
- Ramps that change direction between runs at landings must have a clear landing measuring at least 60” (W) x 60” (L).

The requirements for a compliant ramp are stated in the 2010 Standards at Section 405 and are largely unchanged from the 1991 Standards. Requirements for other components of an

accessible route (elevators, lifts, and curb ramps) can be found in the 2010 Standards at Sections 206, 406, 407, 408, and 410.

e. Protruding Objects

Many individuals who are blind or have low vision use canes to detect objects in their path. However, the cane detection method only detects objects that are 27” or less above the ground. Thus, objects located outside of this cane detection area can present a safety hazard to individuals who are blind or have low vision.

Objects that are wall or ceiling mounted may not project more than 4” into walks, halls, corridors, passageways or aisles unless they are at or below 27” above finished floor (AFF), or higher than 80” AFF. (The 2010 Standards uses the term “circulation paths.”) Some common objects in lodging facilities include water fountains, stairs with open areas underneath, wall-mounted fixtures (*e.g.*, lights, artwork, televisions), fire extinguishers, exit signs, and telephones.

2010 STANDARDS FIGURE 307.2

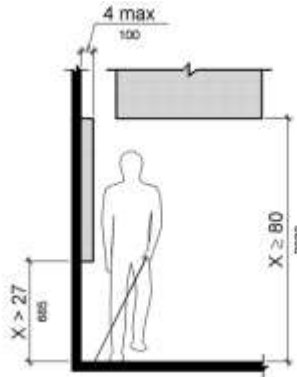

If an object is located above 27” and below 80” AFF and protrudes more than 4” into the path of travel, it must have a permanent barrier below that is detectable at 27” AFF or less (*e.g.*, an open stair must have a railing or fixed object in areas below the portion of the underside of the stair that is less than 80” AFF), or be placed in an alcove so that it no longer protrudes into the circulation path.



Example of water fountains placed into an alcove so that they do not protrude into the circulation path.

Free-standing objects mounted on posts or pylons can protrude up to 12” beyond the farthest reaching detectable element when located 27” to 80” AFF (*see* figure (a) below). When an object is mounted between posts or pylons and the distance between the posts or pylons is greater than 12”, the lowest edge of the object must be no higher than 27” AFF, or at least 80” AFF (*see* figure (b) below).

2010 STANDARDS FIGURE 307.3

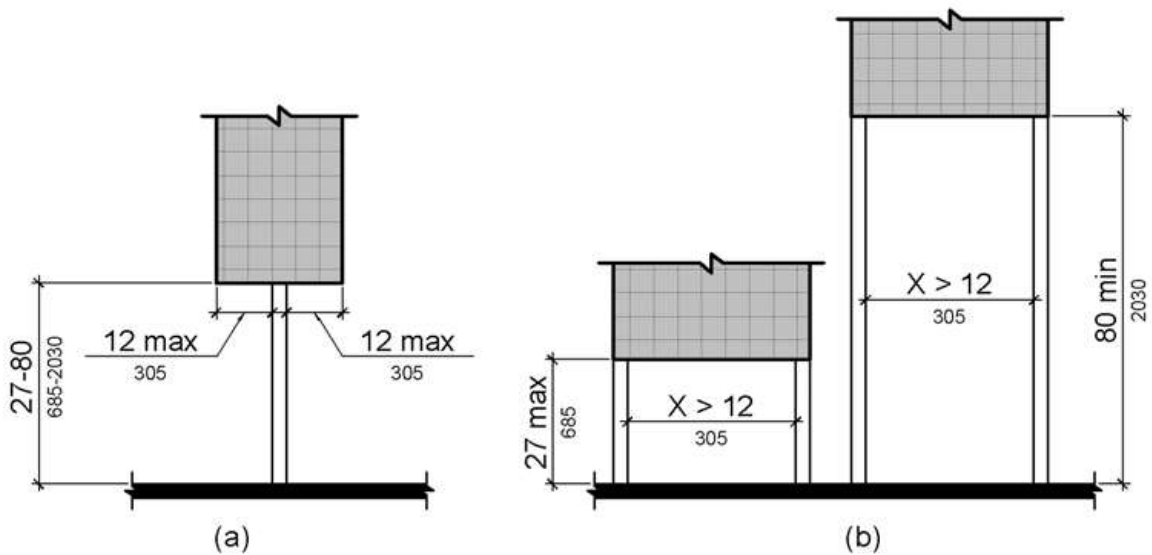

f. Turning Spaces

Wheelchair turning space is required in virtually all spaces required to be accessible. There are two types of turning spaces:

- 60” diameter turning radius (the turning space may include space provided for knee and toe clearance underneath fixtures such as an accessible sink); and
- Space for a T-turn, as shown in the following diagram:

2010 STANDARDS FIGURE 304.3.2

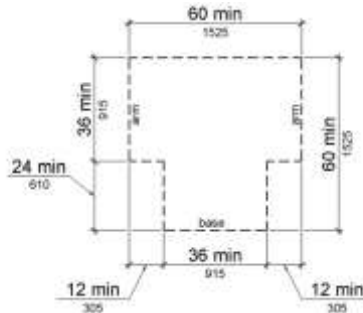

If a T-turn space is provided, only the space at the bottom of one arm or the base of the T can overlap any space provided under a fixture for knee and toe clearance.

The requirements for turning spaces can be found in the 2010 Standards at Section 304.

g. Doors and Entrances

Both the 1991 Standards and the 2010 Standards have specific requirements for accessible doorways and public entrances, and they differ as follows:

| | 1991 STANDARDS | 2010 STANDARDS |
|----------------------------|---|---|
| Public Entrances | 50% ⁸ of public entrances, but never fewer than the number of exits required by state or local code, must be accessible. | 60% of public entrances must be accessible. |
| Parking Structure Entrance | One entrance from a parking structure where there is direct pedestrian access must be accessible. | All entrances where there is direct pedestrian access must be accessible. |

The general requirements for accessible entrances can be found in the 2010 Standards at Section 206. Generally, every space that is required to be accessible must have an accessible doorway, and all doorways along an accessible route must also be accessible. However, lodging

⁸ The 2010 Standards Section 104.2 states that when percentages are used to determine the number of required elements or facilities, fractions should be rounded up.

facilities should keep in mind that both the 1991 Standards and the 2010 Standards require that all passage doors in guest rooms—even if they are non-accessible guest rooms—provide 32” minimum of clear width.

An accessible doorway or entrance must meet the following requirements:

- Be on an accessible route;
- Not be a revolving door, revolving gate, or turnstile;
- Provide a 32” minimum clear opening width when open at 90 degrees (at a double door, at least one panel must provide this clear opening width);
- Passage doorways more than 24” deep must provide a minimum clear opening of 36”. This may apply to a recessed door or a door located in an alcove;
- Threshold is no greater than ¼” or ½” with 1:2 bevel (existing or altered thresholds may be as high as ¾” with a 1:2 bevel);
- Door hardware can be used without tight grasping, pinching, or twisting of the wrist;
- Door hardware must be located between 34” and 48” AFF. There is an exception for access gates protecting pools, spas, and hot tubs: The operable parts of the release of latch on self-latching devices may be no more than 54” AFF provided the self-latching device is not also a self-locking device and operated by a key, electronic opener, or integral combination lock (2010 Standards only);
- If the door is an interior door and not a fire door, the force required to open the door cannot exceed 5 pounds;
- The door takes at least three seconds to close from an open position of 70 degrees to a point 3” from the latch (1991 Standards), or at least 5 seconds from any open position of 90 degrees to a position of 12 degrees from the latch (2010 Standards only);
- There must be no projections (*e.g.*, door hardware) into the clear opening width lower than 34” (2010 Standards only);
- Projections between 34” and 80” AFF must be no greater than 4” (*e.g.*, panic bars) (2010 Standards only);
- Swinging door and gate surfaces within 10” of the floor (measured vertically) must have a smooth surface on the push side that extends the full width of the door or gate (2010 Standards only);

- If there are two doors in a series, there must be 48” of space in the vestibule when both doors are in the open position (2010 Standards Fig. 404.2.6); and
- Maneuvering clearance on both sides of the door complies with one of the diagrams shown below:

2010 STANDARDS FIGURE 404.2.4.1

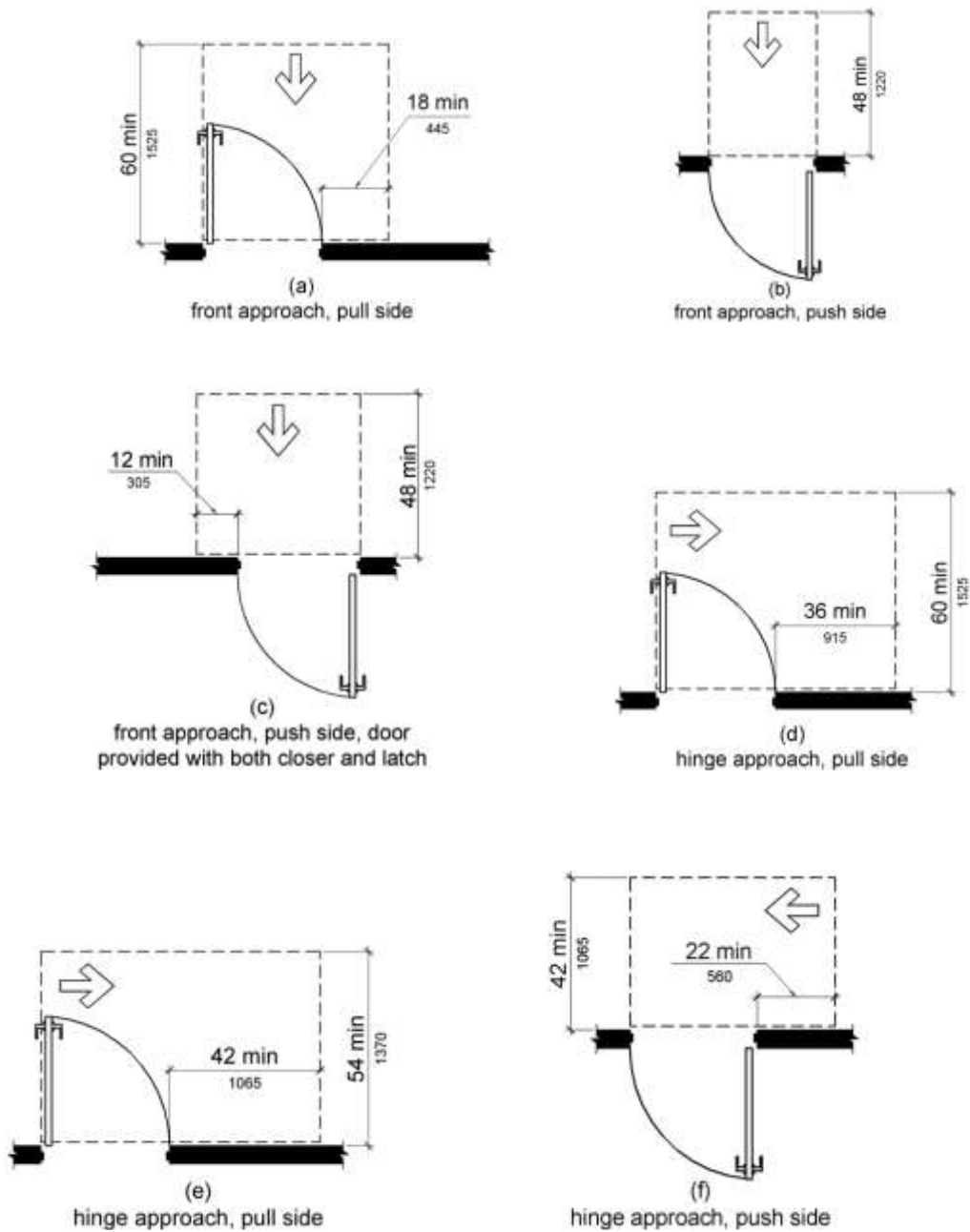

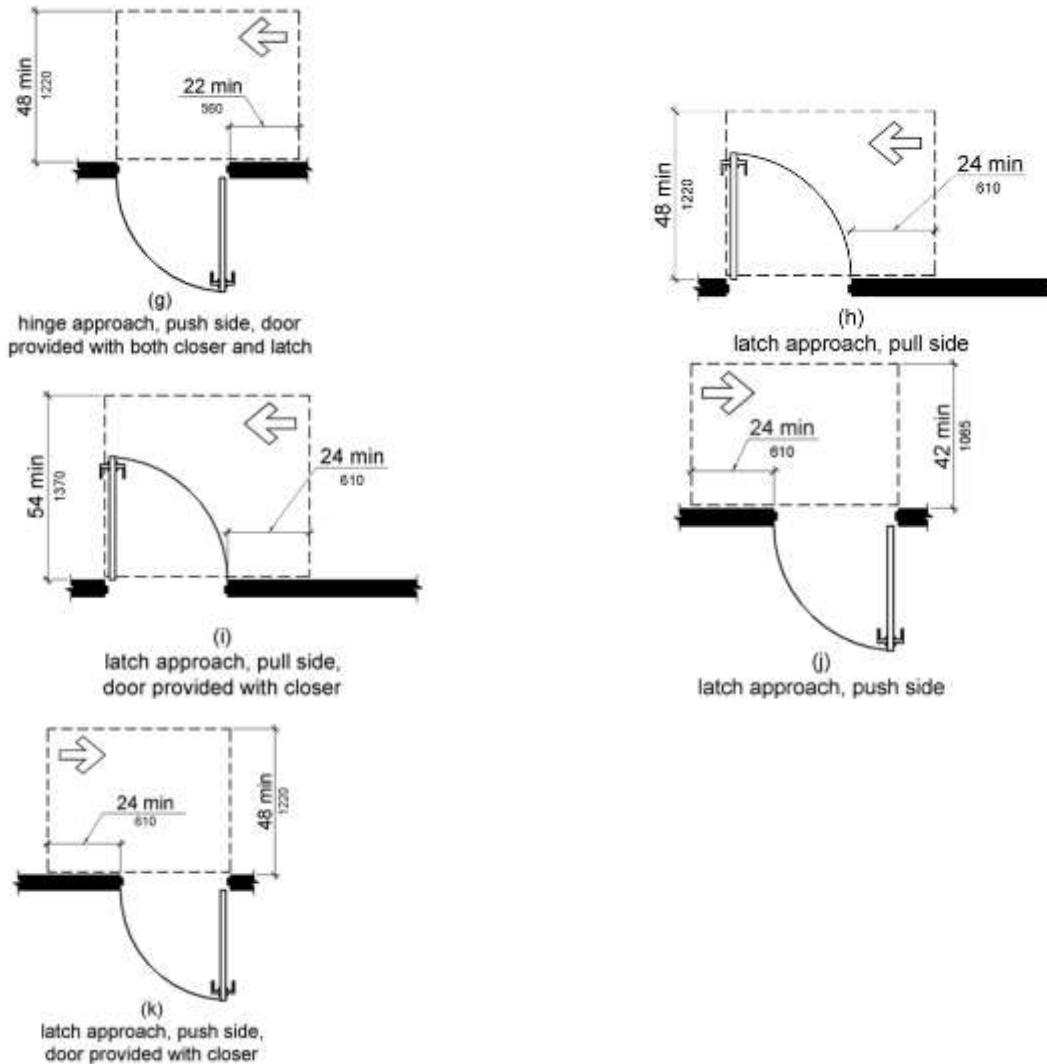

A common complaint from individuals with disabilities is that doors in lodging facilities are too heavy to operate. Neither the 1991 Standards nor the 2010 Standards require automatic door openers, but they do specify that the force required to open interior doors cannot exceed five pounds, unless the door is a fire door for which the fire authorities prescribe a different opening force. Relatively easy steps that a lodging facility can take to reduce the force required to open a door include adjusting or replacing the door closers. If a door does have an automatic door opener, it must comply with the applicable ADA standards (1991 Standards Section 4.13.12 or 2010 Standards Section 404.3).

If a lodging facility has public entrances that are not accessible, there must be signage posted at these entrances indicating the location of the accessible entrance(s). (See Section IV.E.1 (i) of this guide for signage requirements.). In addition, the accessible entrances must be marked with the International Symbol of Accessibility (ISA) shown below (2010 Standards Fig. 703.7.2.1):



h. Access to Operable Parts and Self-Service Items

The 1991 Standards and the 2010 Standards contain requirements designed to ensure that individuals with mobility disabilities have access to controls and other items that guests are expected to use in a lodging facility. Some examples include:

- In accessible guest rooms: Controls for lamps, light switches, thermostats, draperies, clothing rods, makeup mirrors, coffee makers, outlets, safes, hooks, towel storage fixtures, ironing equipment, and hair dryers.
- In public spaces: Telephones, self-service food and beverage items, dispensers and hooks in restrooms, ATMs, fire alarm pulls, card readers, vending machines, and towels at the gym and pool.

These requirements pertain to the location of the controls or items relative to the individual with a disability who is using a wheelchair (*i.e.*, clear floor space and reach range) and the force and motion required to operate the control.

(i) Clear Floor Space

In order for a person using a wheelchair to access a control or item, it must be on an accessible route and there must be a 30" x 48" clear floor space adjacent to the control or item. This is the footprint for the wheelchair. When special conditions such as alcoves exist, a larger clear floor space is required. The 30" x 48" clear floor space can be positioned for a side approach (*i.e.*, the control is to the side of the wheelchair) or front approach (*i.e.*, the control is in front of the wheelchair).

2010 STANDARDS FIGURE 305.5

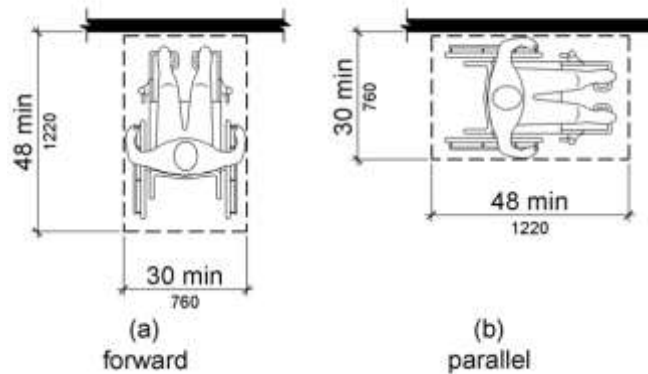

(ii) Reach Range

A person who uses a wheelchair will typically not be able to reach as far as a person whose mobility is not limited. Thus, both the 1991 Standards and the 2010 Standards require that controls or other items that guests are expected to use be within “accessible” reach ranges.

To determine what the accessible reach range is for a particular control or item, a lodging facility must first determine whether it can be approached in a wheelchair from the side or the front as discussed above. A side approach generally allows for a greater reach range than a forward approach.

The accessible reach ranges under the 1991 Standards are as follows:

ACCESSIBLE FORWARD REACH UNDER 1991 STANDARDS FIGURE 5:

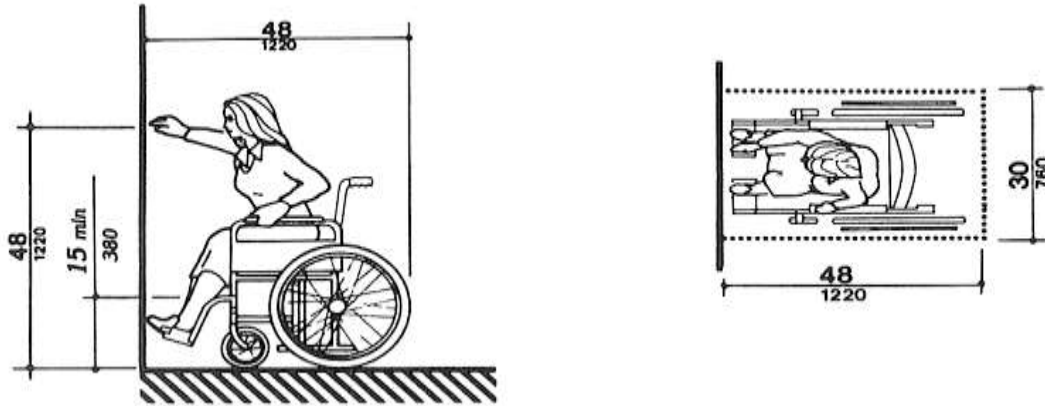

(a)
High Forward Reach Limit

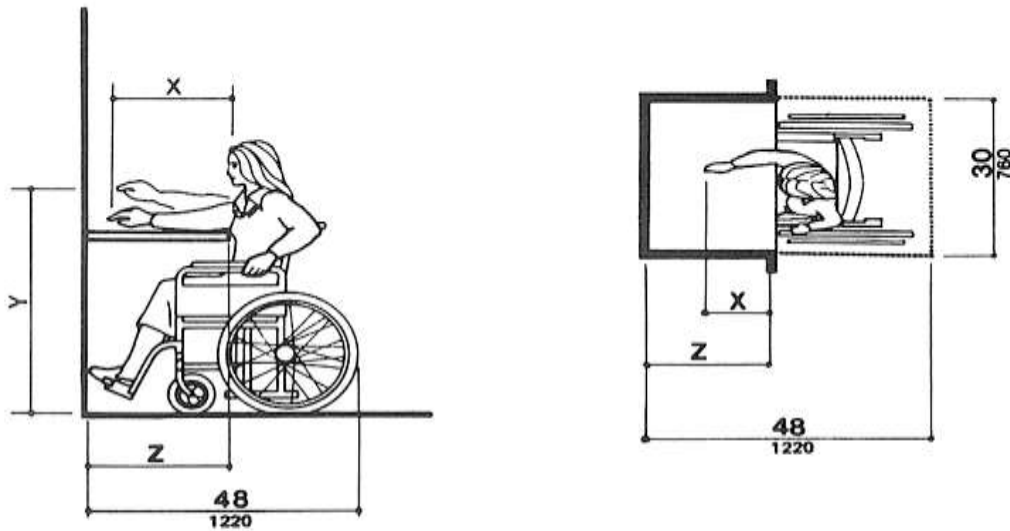

NOTE: x shall be ≤ 25 in (635 mm); z shall be $\geq x$. When $x < 20$ in (510 mm), then y shall be 48 in (1220 mm) maximum. When x is 20 to 25 in (510 to 635 mm), then y shall be 44 in (1120 mm) maximum.

(b)
Maximum Forward Reach over an Obstruction

Fig. 5
Forward Reach

ACCESSIBLE SIDE REACH UNDER 1991 STANDARDS FIGURE 6

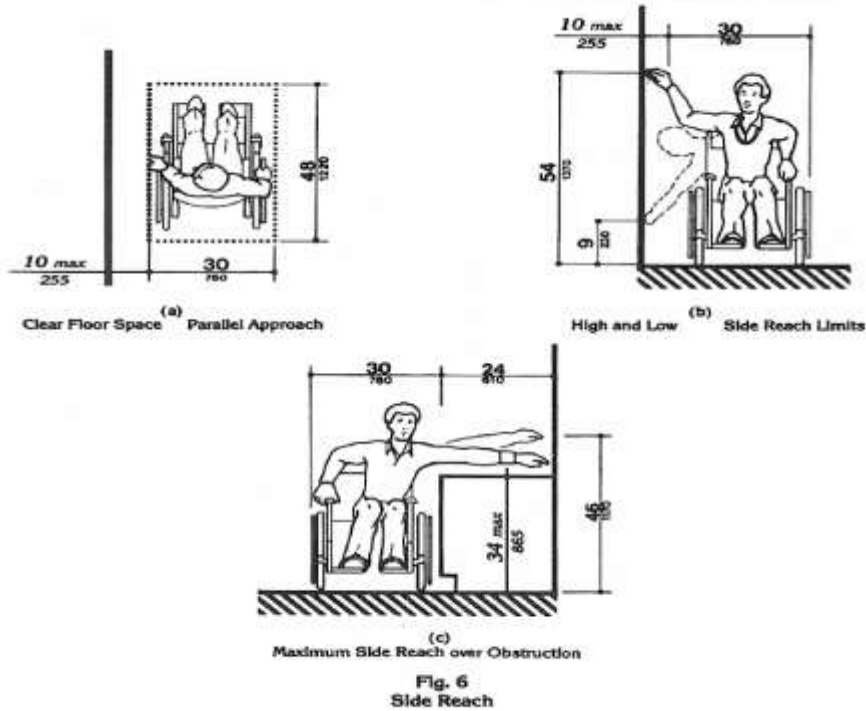

Under the 1991 Standards, if there is space for a side approach, the accessible reach range is 9” to 54” AFF, assuming the person does not have to reach in more than 10” (See Fig. 6(b)). If there is only a front approach, the accessible reach range is 15” to 48” AFF (See Fig. 5(a)). If a person has to reach over an obstruction (e.g., a counter), the rules are different (See Figures 5(b) and 6(c)).

The 2010 Standards reduce the unobstructed side reach range of 9”-54” to 15”-48” AFF. All other requirements remain the same.

These reach ranges apply to elements such as self-service food buffets, telephones, vending machines,⁹ light switches, thermostats, towel racks, closet rods, and irons and ironing boards in accessible guest rooms.

As discussed in Sections IV.A and IV.C above, elements that already comply with the 1991 Standards as of March 15, 2012 are in a “safe harbor” and do not have to comply with the 2010 Standards until they are altered.

⁹ The 1991 Standards only require a clear floor space for vending machines and do not impose a reach requirement. The 2010 Standards require vending machine controls and operable parts to comply with reach range requirements.

(iii) Operability

Controls must be operable with less than 5 pounds of force and without requiring tight grasping, pinching, or twisting of the wrist. This requirement exists because some people with mobility disabilities have limited hand strength and control. Round knobs or rods (used for draperies) generally are not accessible. Lever hardware, push button controls, D-pulls, or loop controls usually are accessible.

i. Signage

The 1991 Standards and 2010 Standards contain very detailed requirements for various types of signage found in a lodging facility. Lodging facility owners and operators should review the requirements carefully. As a general matter, signage falls into two categories: (1) signage designating permanent rooms and spaces; and (2) directional signage.

(i) Signage Designating Permanent Rooms and Spaces

Signs designating permanent rooms and spaces (*e.g.*, guest rooms, restrooms, business and fitness centers, meeting rooms) must have raised (*i.e.*, tactile) lettering, Braille, a non-glare finish, and high contrast between the background and characters (*e.g.*, light letters on a dark background or dark letters on a light background). Signs with metallic finishes usually are not compliant because they are shiny. There are also very specific requirements for character height and proportions that can be found in the 2010 Standards at Section 703.

The 1991 Standards and the 2010 Standards also specify where the signs must be mounted. The following comparison chart summarizes the signage mounting location requirements under the 1991 Standards and the 2010 Standards:

| 1991 STANDARDS | 2010 STANDARDS |
|---|---|
| 60" to the center of the sign from the finished floor. | 48" minimum AFF (measured to the baseline of the lowest tactile character) and 60" maximum AFF (measured from the baseline of the highest tactile character). |
| Person should be able to be within 3" of the sign without encountering a protruding object or standing within door swing. | 18" x 18" clear floor space outside of door swing, centered on tactile letters (<i>see</i> Figure 703.4.2 below). |
| For single doors, latch side of door. | Same as 1991 Standards. |
| If insufficient space on latch side, sign should be on the nearest adjacent wall. | Same as 1991 Standards. |
| For double doors, sign should be on the nearest adjacent wall. | For double doors with one active leaf, sign should be on inactive leaf. For double doors with two active leaves, sign should be to the right of the right hand door. |
| Sign not allowed on door. | Sign can be mounted on door on push side if there is a closer and no hold open device. |

**Figure 703.4.2
Location of Tactile Signs at Doors**

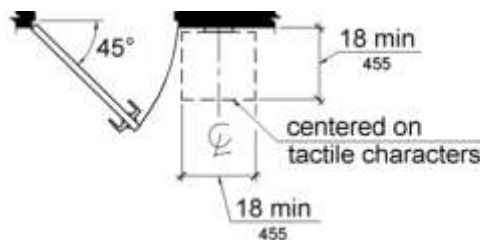

(ii) Directional Signage

Directional signs do not need Braille or raised letters. However, they must be high contrast and have a matte, non-glare finish. There are also specific requirements for the size and spacing of characters. As discussed in other sections, directional signage is necessary when a space or element is not accessible because individuals with disabilities need to know where the

accessible space or element is located (*e.g.*, location of accessible entrance, restroom, route to a location).

Specific details about signage requirements can be found in the 2010 Standards at Sections 216 and 703.

2. Accessible Parking

One of the first areas that a guest may encounter upon arrival at a lodging facility is the parking lot. Providing accessible parking for individuals with disabilities is extremely important not only because some individuals with disabilities cannot travel long distances, but also because individuals who use wheelchairs and other mobility devices need the parking space access aisle to get in and out of their vehicles.

There are two types of accessible parking spaces: car accessible spaces and van accessible spaces.

- Car accessible space requirements:
 - 8' (W), level, with a maximum 2% slope in all directions;
 - Adjacent 5' (W), level access aisle that extends the full length of the parking space(s) it serves (two spaces can share one access aisle), and is marked to prevent vehicles from parking in the aisle; and
 - Signage showing the ISA mounted at least 60" AFF (measured to the bottom of the sign). Note: The 1991 Standards do not specify a specific height measurement, but the sign must be high enough to be seen over a parked car.
- Van accessible space requirements:
 - 11' (W), level, with a maximum 2% slope in all directions;
 - Adjacent 5' (W), level access aisle that extends the full length of the parking space(s) it serves (two spaces can share one access aisle), and is marked to prevent vehicles from parking in the aisle. Alternatively, a van accessible space can be 8' (W) with an 8' (W) access aisle;
 - Signage showing the ISA and the words "van accessible," mounted at least 60" AFF (measured to the bottom of the sign). Note: The 1991 Standards do not specify a specific height measurement, but the sign must be high enough to be seen over a parked car); and

- Overhead clearance of 98". In a covered parking structure, this clearance must be maintained on the entire route connecting the entrance, parking space, and exit.

2010 STANDARDS FIGURE 502.2

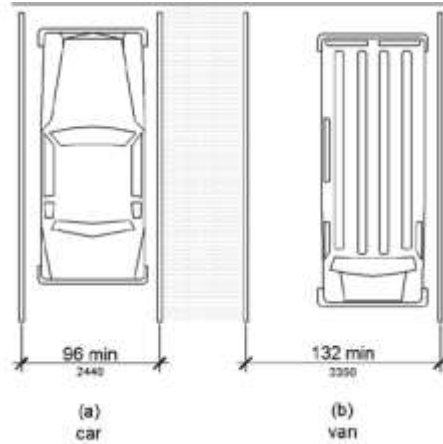

Parking lots and parking structures are considered separate parking facilities. The number of required car and van accessible spaces is determined by looking at the total number of parking spaces per facility as indicated on the following chart:

2010 STANDARDS TABLE 208.2

| Total Number of Parking Spaces Provided in Parking Facility | Minimum Number of Required Accessible Parking Spaces |
|--|---|
| 1 to 25 | 1 |
| 26 to 50 | 2 |
| 51 to 75 | 3 |
| 76 to 100 | 4 |
| 101 to 150 | 5 |
| 151 to 200 | 6 |
| 201 to 300 | 7 |
| 301 to 400 | 8 |
| 401 to 500 | 9 |
| 501 to 1,000 | 2 percent of total |
| 1,001 and over | 20, plus 1 for each 100, or fraction thereof, over 1,000 |

The number in the second column indicates the number of total accessible spaces required under both the 1991 Standards and the 2010 Standards. Under the 1991 Standards, 1 in 8 accessible spaces (or a minimum of 1, whichever is greater) must be van accessible. The 2010 Standards change that ratio to 1 in 6. A parking facility that complies with the 1991 Standards requirement for van accessible spaces as of March 15, 2012 does not need to add more van accessible spaces until it is altered.

Example: A lodging facility parking lot has 400 spaces. Therefore, 8 accessible spaces are required. Under the 1991 Standards, 1 of those 8 spaces must be van accessible and the other 7 must be car accessible. Under the 2010 Standards, 2 of those spaces must be van accessible and 6 must be car accessible.

Accessible parking spaces must be the closest spaces on an accessible route to the accessible entrances. When the parking serves more than one accessible entrance, accessible parking must be dispersed and located on the shortest accessible route to the accessible entrances. In a multi-story parking facility, van accessible parking spaces can be grouped on one level.

The accessible parking requirements can be found in the 2010 Standards at Sections 208 and 502.

3. Passenger Loading Zones

Most lodging facilities provide passenger loading zones at one or more entrances. If a passenger loading zone is provided, it must be accessible. The requirements for passenger loading zones are somewhat different in the 1991 Standards and the 2010 Standards. The following requirements are from Section 503 of the 2010 Standards, with differences from the 1991 Standards noted:

- Vehicle pull-up space must be at least 8' (W) and 20' (L); and
- Access aisle adjacent to the vehicle pull-up space must be;
 - Adjacent to an accessible route;
 - A minimum 60" (W);
 - Same length as the vehicle pull-up space;
 - On the same level as the vehicle pull-up space (Note: The 1991 Standards do not contain this requirement); and
 - Marked to discourage vehicles parking in the space. (Note: The 1991 Standards do not require marking of the access aisle, but do require the ISA to be displayed at the accessible passenger loading zone.)

- Both the vehicle pull-up space and the access aisle serving it must:
 - Be firm, stable, and slip resistant;
 - Have a maximum 2% slope in all directions;
 - Not have any openings greater than ½” wide. Grates or elongated openings must run perpendicular to the main direction of travel; and
 - Have vertical clearance that is at least 114” high. (Note: The 1991 Standards do not contain this requirement.)

2010 STANDARDS FIGURE 503.3

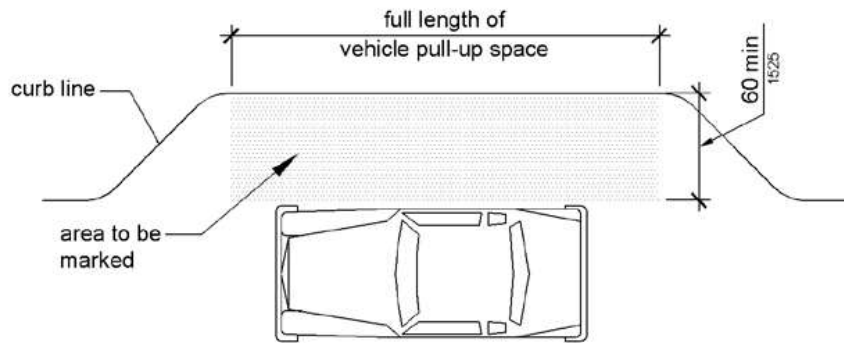

4. Sales and Service Counters

Both the 1991 Standards and the 2010 Standards contain the following requirements for sales or service counters:

- One of each type of sales or service counter (*e.g.*, lodging facility registration, spa, concierge, car rental counters) must be accessible.
- If sales and service counters are dispersed throughout a facility, accessible counters must also be dispersed.

The 1991 Standards and the 2010 Standards contain different specifications for an “accessible counter.” Under the 1991 Standards, an accessible counter is one that has a lowered section that is 36” long and no higher than 36” AFF. However, for counters where there are no cash registers, the 1991 Standards allow alternatives such as an auxiliary counter, fixed shelf, or pull-out shelf that is no higher than 36” but not necessarily 36” wide.

The 2010 Standards do not allow for the auxiliary counter, fixed shelf, or folding shelf options at counters where there are no registers. In addition, the 2010 Standards state for the first time that the accessible portion of the counter must be the full depth of the non-accessible, customer side portion of the counter. The 2010 Standards provide for a new alternative counter

where there is only room for a forward approach to the counter. In that instance, the lowered portion can be at least 30” wide and no higher than 36”, as long as there is knee and toe space under the counter that complies with Section 306 of the 2010 Standards.



Example of accessible service counter with a lowered 36” (W) and 36” (H) section.

The requirements for sales and service counters can be found in the 1991 Standards at Section 7.2, and in the 2010 Standards at Sections 227 and 904. Counters that comply with the 1991 Standards as of March 15, 2012, do not have to comply with the 2010 Standards until they are altered.

5. Public Restrooms

The 1991 Standards and the 2010 Standards require every public restroom to be accessible. If a pre-ADA lodging facility has inaccessible restrooms, it must post signage at those restrooms stating the location of the nearest accessible restrooms, as well as signage with the ISA at the entrance to the accessible restrooms.

The accessibility features required in an accessible restroom under the 1991 Standards are as follows:

- Wheelchair turning space;
- An accessible sink (*see* section (a) below);
- A wheelchair accessible stall with an accessible toilet (*see* section (b) below);
- If urinals are provided, a lowered urinal with a rim that is 17”-19” AFF;
- If there are six or more stalls, one must be an accessible ambulatory stall (*see* section (c) below);
- A mirror over the accessible sink that is mounted so that the bottom reflective edge is no higher than 40” AFF;

- Dispensers mounted so that the controls and dispensing points are within accessible reach ranges; and
- Dispensers with controls that do not require tight grasping, pinching, or twisting of the wrist or more than 5 pounds of force to operate.

The 2010 Standards differ from the 1991 Standards in the following ways:

- If there are six or more stalls *or urinals combined* (as opposed to just stalls under the 1991 Standards), then an accessible ambulatory stall is required; and
- If there is an accessible wheelchair stall and only one urinal, the urinal does not have to be accessible.

a. Accessible Sink Requirements

Under the 1991 Standards, an accessible sink must meet the following requirements:

- A top surface no higher than 34" AFF;
- Faucet handles that do not require tight grasping, turning, or twisting of the wrist;
- Pipes that are insulated or covered to prevent burns and abrasions; and

- Clearance underneath the sink that complies with the following diagrams:

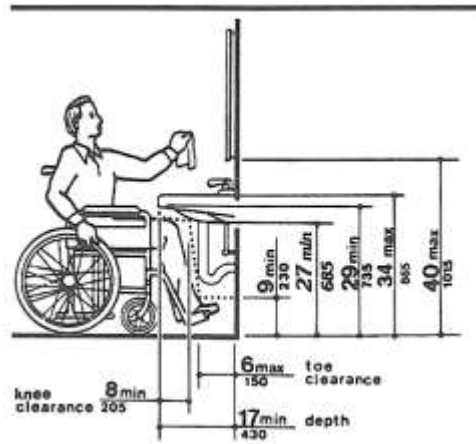

Fig. 31
Lavatory Clearances

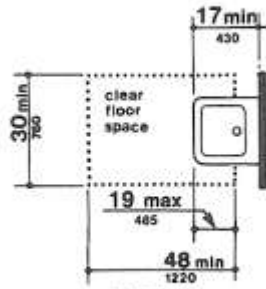
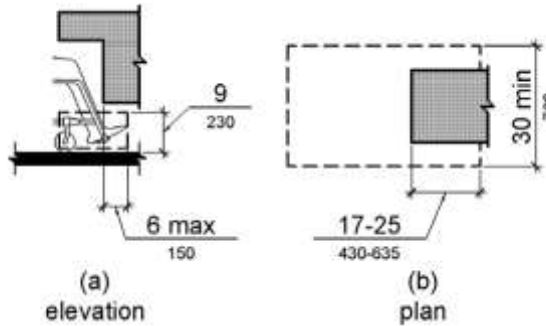

Fig. 32
Clear Floor Space at Lavatories

The 2010 Standards eliminate the requirement for 29” of clearance under the sink apron. Instead, the 2010 Standards contain the following knee and toe clearance requirements:

2010 STANDARDS FIGURE 306.2



2010 STANDARDS FIGURE 306.3

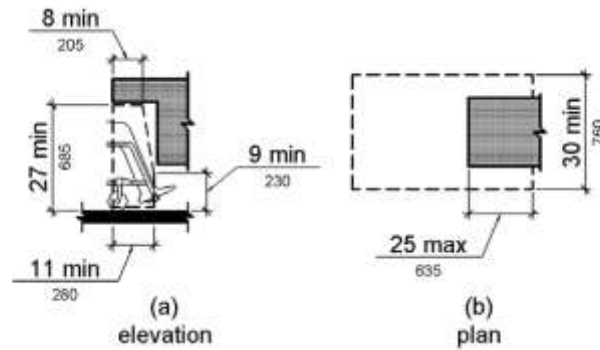

Example of accessible sink with knee and toe clearance, insulated pipes, and mirror with bottom edge at below 40" AFF.

b. Wheelchair Accessible Stalls

Assessing the compliance of a toilet stall with the applicable ADA standards can be challenging and is best done by an ADA consultant or architect. However, the general requirements are as follows:

- Under the 1991 Standards and the 2010 Standards, there are a number of permissible accessible toilet stall layouts. However, the basic minimum size and layout of the stall must be as follows:

2010 STANDARDS FIGURE 604.8.1.1

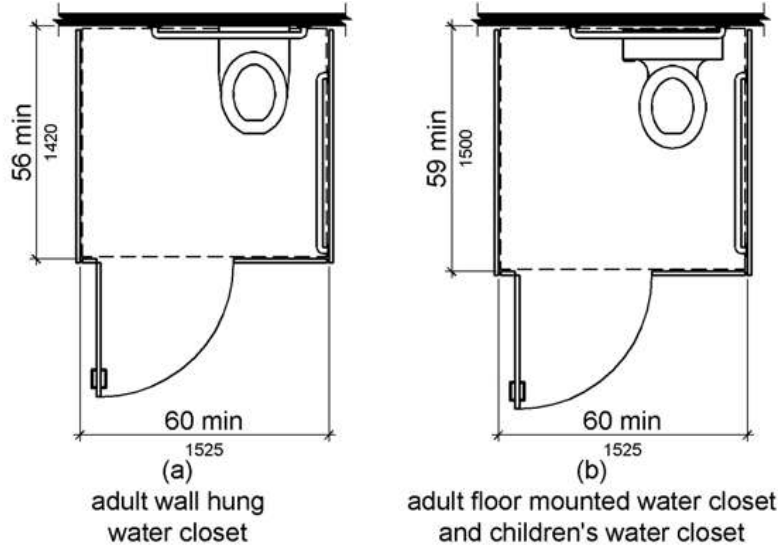

- The front partition and one side partition must provide toe clearance of 9" AFF and min. 6" deep beyond the compartment side face of the partition, unless the compartment is greater than 62" deep with a wall hung toilet or 65" deep with a floor mounted toilet.
- The centerline of the toilet must be 18" from the nearest side wall under the 1991 Standards, or 16-18" under the 2010 Standards.
- The height of the toilet must be between 17-19" from the floor (measured to the top of the seat).
- The flush control must be on the open side.
- There must be a 36" rear grab bar and a 42" side grab bar around the toilet mounted as shown below:

2010 STANDARDS FIGURE 604.5.2

Rear Wall

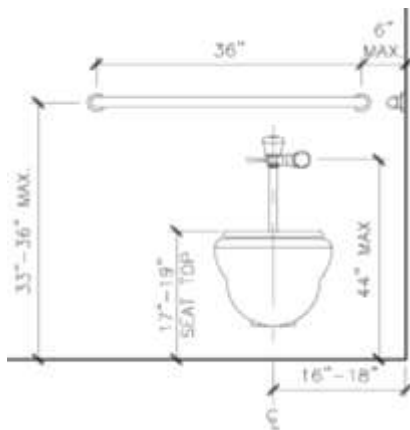
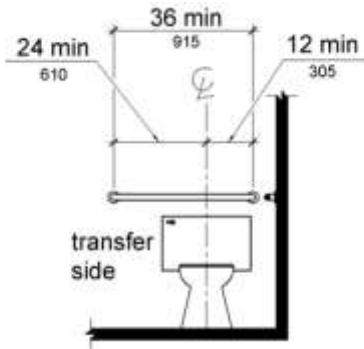

2010 STANDARDS FIGURE 604.5.1

Side Wall

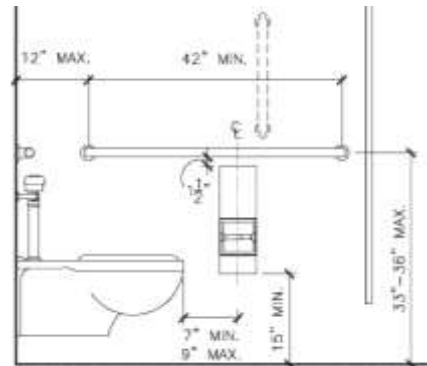
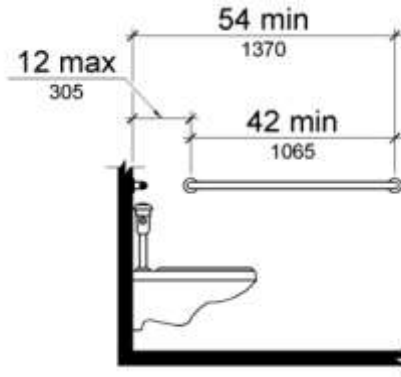

Water Closet and Grab Bar Elevations

- Grab bars must meet the technical requirements set forth in the standards.
- The centerline of the toilet paper dispenser must be at least 19" AFF and no more than 36" from the rear wall (1991 Standards), or 7"-9" in front of the toilet rim and at least 15" AFF (2010 Standards) as shown below:

ADA 2010 STANDARDS FIGURE 604.7

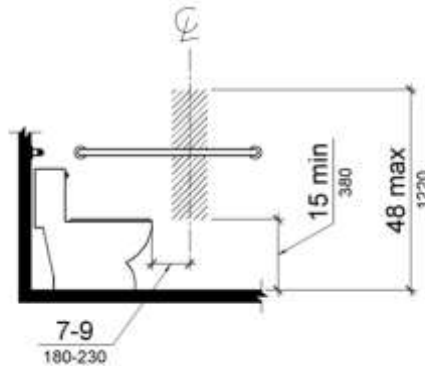

- Any hooks or dispensers inside the stall must have control/access points that are no more than 48" AFF (54" for a side approach under the 1991 Standards).
- There must be a 30" x 48" clear floor space next to each control and/or dispenser.
- Objects must be mounted at least 12" above the grab bars.
- The door to the stall must be self-closing.
- There must be a door pull on the inside and outside of the door.
- The hardware on the stall must be operable without tight grasping, pinching, or twisting of the wrist; and
- If the approach is from the latch side of the compartment door, there must be 42" between the face of the door (closed position) and any obstruction.

c. Ambulatory Accessible Stalls

The 1991 Standards require one (1) ambulatory accessible stall in restrooms with six (6) or more stalls. Under the 1991 Standards, an ambulatory accessible stall must have the following features:

- Be 36" (W) and at least 60" (D);
- The door to the stall must provide 32" (W) min. clear width and be outward-swinging and self-closing;
- The centerline of the toilet must be 18" from the side wall;
- The top of the toilet seat must be 17" -19" AFF;

- The flush valve must be a maximum of 44” AFF and require no more than 5 pounds of force to operate;
- Parallel grab bars are provided on both sides of the stall that are at least 42” (L) and are mounted no more than 12” from the rear wall and at least 24” in front of the toilet (measured to the front end of the grab bar);
- Grab bars must meet the technical requirements set forth in the standards;
- The toilet paper dispenser must be mounted no more than 36” from the rear wall (measured to the front of the dispenser), below the grab bar within 12” of the front edge of the toilet seat, and at least 19” (H) AFF (measured to the centerline of the dispenser); and
- Controls must be operable with one hand and not require tight grasping, pinching, or twisting of the wrist.

The 2010 Standards differ from the 1991 Standards in the following ways:

- Under the 2010 Standards, one (1) ambulatory stall is required in restrooms with 6 or more stalls *or urinals combined* (the 1991 Standards count only toilet stalls for this purpose);
- An ambulatory accessible stall must be 35” to 37” (W);
- If the approach to the stall is from the latch side of the compartment door, there must be 42” min. between the face of the door (closed position) and any obstruction;
- The centerline of the toilet paper dispenser must be 7”-9” in front of the toilet rim and at least 15” AFF; and
- There must be a door pull on the inside and outside of the door.

The requirements for restrooms elements can be found in the 2010 Standards at Sections 213, 603, and 604.

6. Accessible Guest rooms

For an individual with a disability, staying in an accessible guest room with features that meet his or her needs is a top priority. All employees involved with the assignment and reservation of rooms at a lodging facility should understand the different types of features that an accessible room can have so that guests are assigned appropriate rooms.

a. Accessible Rooms Overview

The term “accessible room” refers to a room that has features for individuals with disabilities. However, there are different types of accessible rooms. Both the 1991 Standards

and the 2010 Standards require a certain number of accessible rooms that have features for those with mobility disabilities, and a certain number of accessible rooms with communications features (*i.e.*, visual fire alarms and visual notification devices for incoming telephone calls and doorbell/door knock) for individuals who are deaf or hard hearing. Accessible rooms with mobility features can be further broken down based on whether they have roll-in showers, accessible tubs, or transfer showers.

The 1991 Standards require that *all* mobility accessible rooms have communications features for individuals who are deaf or hard of hearing. They also require a separate set of accessible rooms that only have communications features. The 2010 Standards take a different approach: They require the same number of rooms with mobility features and the same number of rooms with communications features, but do not allow more than 10% of the rooms with mobility features to also have communications features. At least one accessible room must have both mobility and communications features.

The change from the 1991 Standards to the 2010 Standards is shown in the following diagram:

1991 Standards

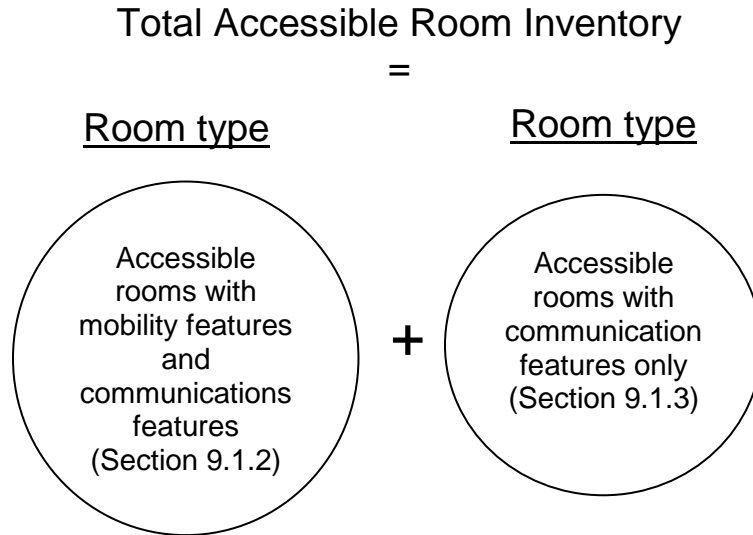

2010 Standards

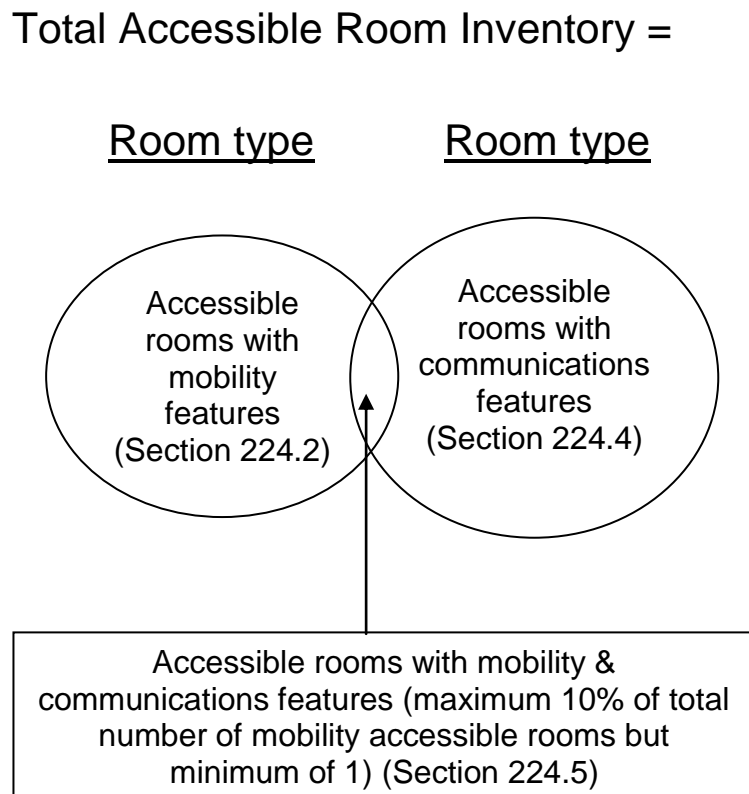

b. Calculating the Number of Required Accessible Rooms

(i) 1991 Standards

The following chart shows the number of rooms that must have both mobility and communications features under the 1991 Standards:¹⁰

1991 STANDARDS SECTION 9.1.2

| <u>Number of Rooms</u> | <u>Accessible Rooms</u> | <u>Rooms with Roll-in Showers</u> |
|-------------------------------|------------------------------------|--|
| 1 to 25 | 1 | |
| 26 to 50 | 2 | |
| 51 to 75 | 3 | 1 |
| 76 to 100 | 4 | 1 |
| 101 to 150 | 5 | 2 |
| 151 to 200 | 6 | 2 |
| 201 to 300 | 7 | 3 |
| 301 to 400 | 8 | 4 |
| 401 to 500 | 9 | 4, plus one for each additional 100 over 400 |
| 501 to 1,000 | 2 percent of total | |
| 1,001 and over | 20, plus 1 for each 100 over 1,000 | |

¹⁰ A common misunderstanding is that the numbers in the Section 9.1.2 chart are only for mobility accessible rooms. In fact, 1991 Standards Section 9.1.2 requires these rooms to also have communications features for the deaf or hard of hearing.

The following chart shows the number of rooms with only communications features that must be provided under the 1991 Standards:

1991 STANDARDS SECTION 9.1.3

| <u>Number of Elements</u> | <u>Accessible Elements</u> |
|---------------------------|------------------------------------|
| 1 to 25 | 1 |
| 26 to 50 | 2 |
| 51 to 75 | 3 |
| 76 to 100 | 4 |
| 101 to 150 | 5 |
| 151 to 200 | 6 |
| 201 to 300 | 7 |
| 301 to 400 | 8 |
| 401 to 500 | 9 |
| 501 to 1,000 | 2 percent of total |
| 1,001 and over | 20, plus 1 for each 100 over 1,000 |

Based on these two charts, a lodging facility with 400 rooms would be required to have:

- 12 rooms with both mobility and communications features, 4 of which must have roll-in showers (the other 8 rooms must each have an accessible bathing fixture which can either be a roll-in shower, transfer shower, or accessible tub with grab bars);¹¹ and
- 8 rooms with only communications features.

Thus, this lodging facility would have 20 rooms with communications features and 12 rooms with mobility features. But, because all rooms with mobility features also have communications features, there are only a total of 20 “accessible” rooms.

¹¹ Lodging facilities that provide tubs in non-accessible rooms should provide accessible rooms with tubs to avoid claims that this feature is not available for guests with disabilities.

(ii) **2010 Standards**

The 2010 Standards take a different approach to accessible rooms. The following chart shows the number of rooms that must have mobility features under the 2010 Standards:

| Table 224.2 Guest Rooms with Mobility Features | | | |
|---|--|--|--|
| Total Number of Guest Rooms Provided | Minimum Number of Required Rooms Without Roll-in Showers | Minimum Number of Required Rooms With Roll-in Showers | Total Number of Required Rooms |
| 1 to 25 | 1 | 0 | 1 |
| 26 to 50 | 2 | 0 | 2 |
| 51 to 75 | 3 | 1 | 4 |
| 76 to 100 | 4 | 1 | 5 |
| 101 to 150 | 5 | 2 | 7 |
| 151 to 200 | 6 | 2 | 8 |
| 201 to 300 | 7 | 3 | 10 |
| 301 to 400 | 8 | 4 | 12 |
| 401 to 500 | 9 | 4 | 13 |
| 501 to 1,000 | 2 percent of total | 1 percent of total | 3 percent of total |
| 1,001 and over | 20, plus 1 for each 100, or fraction thereof, over 1,000 | 10, plus 1 for each 100, or fraction thereof, over 1,000 | 30, plus 2 for each 100, or fraction thereof, over 1,000 |

The following chart shows the number of rooms that must have communications features under the 2010 Standards:

| Table 224.4 Guest Rooms with Communication Features | |
|--|--|
| Total Number of Guest Rooms Provided | Minimum Number of Required Guest Rooms With Communication Features |
| 2 to 25 | 2 |
| 26 to 50 | 4 |
| 51 to 75 | 7 |
| 76 to 100 | 9 |
| 101 to 150 | 12 |
| 151 to 200 | 14 |
| 201 to 300 | 17 |
| 301 to 400 | 20 |
| 401 to 500 | 22 |
| 501 to 1,000 | 5 percent of total |
| 1,001 and over | 50, plus 3 for each 100 over 1,000 |

Using the same 400-room scenario, the lodging facility would have to have 20 rooms with communications features and 12 rooms with mobility features (including 4 with roll-in showers) -- the same as under the 1991 Standards. However, because of the new rule that no more than 10% of the rooms with mobility features (but a minimum of one) can have both mobility and communications features, the total number of rooms that have accessible features is higher. Thus, under the 2010 Standards, a lodging facility with 400 rooms must have:

- 11 rooms with only mobility features (including 4 with roll-in showers);
- 19 rooms with only communications features; and
- 1 room with both mobility and communications features.

Thus, there will be a total of 31 accessible rooms.

c. Dispersion of Accessible Rooms

The 1991 Standards at Section 9.1.4(1) and the 2010 Standards at Section 224.5 both require that lodging facilities disperse their accessible rooms among the various classes of sleeping rooms so that guests needing accessible rooms have an “equivalent” range of options as guests who do not need accessible rooms. The factors to be considered include guest room type, guest room size, price, number of beds, and other amenities comparable to choices provided to other guests. *Determining appropriate accessible room dispersion is a very complex task, and lodging facilities should consult with an experienced ADA attorney in determining appropriate dispersion when building new or altering existing facilities.*

In a 2010 nationwide consent decree settlement with a major hotel company, the DOJ agreed that, at a minimum, a lodging facility that offers non-accessible rooms with one bed, two beds, and suites should have at least one accessible room in each of these categories. In addition, if the view is sufficiently distinctive to warrant higher pricing (*e.g.*, ocean view or Central Park view), or if some non-accessible rooms provide special features like access to a concierge lounge or smoking privileges, the lodging facility also should have accessible rooms with these features. However, the DOJ and private plaintiffs have been known to interpret the dispersion requirements in other settlements and enforcement actions to require accessible rooms in premium room categories that have only one or a few rooms (*e.g.*, presidential suites). For this reason, it is particularly important for lodging facility owners and operators to obtain advice from their attorneys and consultants on this issue.

d. Accessible Rooms with Mobility Features

(i) General Requirements

Among other features, both the 1991 Standards and the 2010 Standards require that a mobility accessible room have:

- Accessible doors (*see* Section IV.E.1.g);

- Accessible turning space in the bathroom and living areas (*see* Section IV.E.1.f);
- An accessible route to all amenities in the room (*e.g.*, bed, desk, closet, bathroom, drapes, climate controls, lights switches) (*see* Section IV.E.1.d). In particular, there must be 36” of space on both sides of the bed in rooms with one bed, or down the middle in rooms with two beds;
- Thermostat, light switches, in-room safe, closet rod and shelf (if provided), drapery controls, and hooks within accessible reach ranges and with the required 30” x 48” clear floor space (*see* discussion in Section IV.E.1.h.);
- Controls on the items stated above that do not require tight grasping, pinching, or twisting of the wrist (*e.g.*, rocker, touch, or push controls);
- Furniture with hardware that does not require tight grasping, pinching, or twisting of the wrist;
- A desk that has clear space underneath that is 27” (H) x 30” (W) x 19” (D) (17” (D) min. under the 2010 Standards) so that a wheelchair can pull under;
- A roll-in shower with a fold-down seat, a transfer shower with a fold-down seat, or a bathtub with grab bars and a tub seat;
- A vanity with clearance underneath for a wheelchair that complies with the diagrams set forth in Section IV.E.5.a. (Under the 2010 Standards, the vanity space in an accessible room must also be comparable to the vanity space provided in a non-accessible room); and
- An accessible toilet, as further described below.
- *Note:* Under the 1991 Standards, a mobility accessible room must also have communications features for guests who are deaf or hard of hearing.

(ii) Accessible Toilet requirements

Under the 1991 Standards, an accessible toilet in a guest room must have:

- A 36” rear grab bar and a 42” side grab bar;
- Clear floor space;
- A flush control on the open side;
- A toilet centerline of 18” from the side wall;

- A toilet paper holder that is within 36" from the rear wall and at least 19" AFF; and
- A seat that is 17"-19" AFF (measured to the top of the seat).

1991 STANDARDS FIGURES 28 AND 29

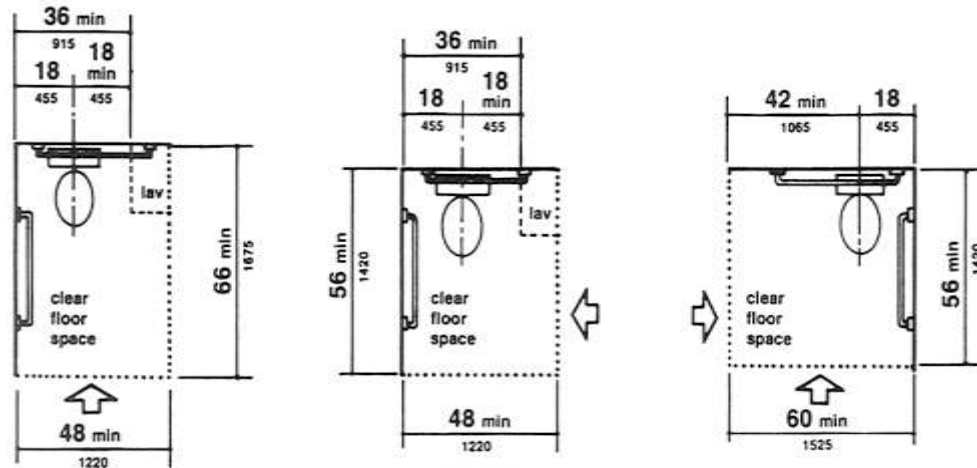

Fig. 28
Clear Floor Space at Water Closets

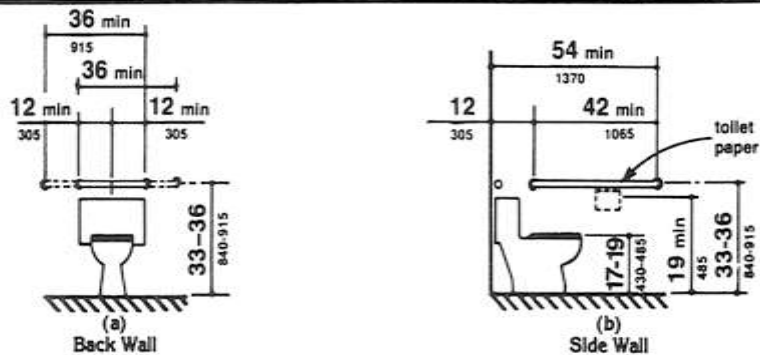
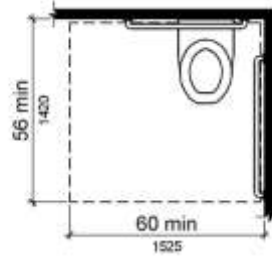

Fig. 29
Grab Bars at Water Closets

The 2010 Standards make three significant changes to the toilet requirements:

- The toilet centerline can be 16"-18" from the side wall rather than 18";
- The 2010 Standards require a minimum 56" (D) x 60" (W) clear space around the toilet *in which a sink cannot be placed*; and
- The toilet paper holder must be 7"-9" in front of the toilet rim, and at least 15".

2010 STANDARDS FIGURE 604.3.1



(iii) Accessible Bathing Fixtures

Roll-in showers. As stated, a specific number of mobility accessible rooms must have roll-in showers. Under the 1991 Standards and the 2010 Standards, roll-in showers in accessible rooms must comply with one of the two following configurations:

2010 STANDARDS FIGURES 608.2.2 AND 608.2.3

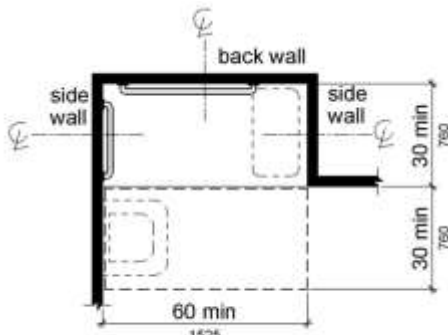

Note: inside finished dimensions measured at the center points of opposing sides

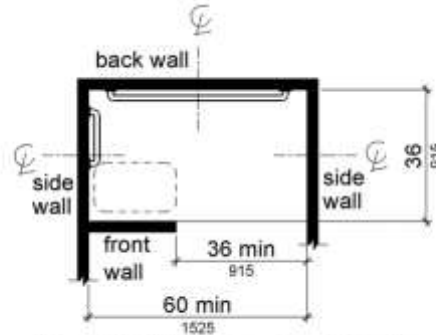

Note: inside finished dimensions measured at the center points of opposing sides

In a shower with the configuration shown in Figure 608.2.2 (left diagram), the controls, faucets, and shower spray unit must be installed above the grab bars but no higher than 48" AFF on the back (*i.e.*, long) wall and located no more than 27" from the seat wall. (*See* 2010 Standards Figure 608.5.2.) The 1991 Standards contain the same requirements but do not specify the height of the controls, faucets, and shower spray unit.

In a shower with the configuration shown in Figure 608.2.3 (right diagram), the controls, faucets, and shower spray unit must be installed above the grab bars, but no higher than 48" AFF either (1) on the side wall adjacent to the seat no more than 27" from the front wall, or (2) on the back wall opposite the seat no more than 15", left or right, from the centerline of the seat. (*See* 2010 Standards Figure 608.5.3.) The 1991 Standards do not provide for the option to put the controls, faucets, and shower spray unit on the back (*i.e.*, long) wall in a shower with the configuration shown in Figure 608.2.3.

All roll-in showers in accessible guest rooms must have permanent fold-down seats. The shower spray unit must be capable of being used as a fixed shower head or as a hand-held shower, and must have a hose that is at least 59" long. Under the 1991 Standards, roll-in

showers may not have any “curbs,” although that term is not specifically defined. The 2010 Standards do explicitly allow thresholds at roll-in showers of no more than ½” with a 1:2 bevel.

Accessible Tubs and Transfer Showers. Accessible rooms that are not required to have roll-in showers must have an accessible bathing fixture, which, under the 1991 Standards, can either be an accessible tub or a transfer shower. There is some question as to whether under the 2010 Standards Table 224.2, the “Minimum Number of Required Rooms Without Roll-in Showers” cannot have roll-in showers and can only have an accessible tub or transfer shower.

There are two styles of accessible tubs: One has a permanent (built-in) seat at the head end of the tub, and the other has a removable seat that is placed in the tub. Most lodging facilities have accessible tubs designed to have a removable seat that can be placed in the tub. *Such lodging facilities should have one removable tub seat for each accessible room that has a tub. The removable tub seat must be capable of being tightly secured to the tub.*

The following diagram shows the two types of accessible tubs:

2010 STANDARDS FIGURE 607.2

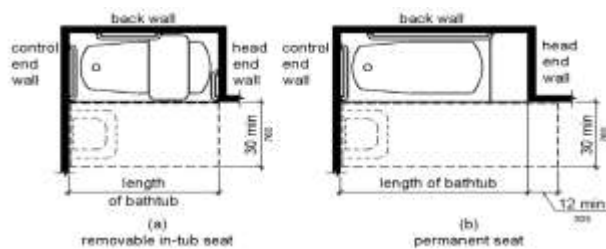

As shown in Figure 607.5 below, controls (other than drain stoppers) for accessible tubs must be:

- located on an end wall;
- between the bathtub rim and the grab bar;
- between the open side of the bathtub and the centerline of the width of the bathtub; and
- operable with one hand and without requiring tight grasping, pinching, or twisting of the wrist.

2010 STANDARDS FIGURE 607.5

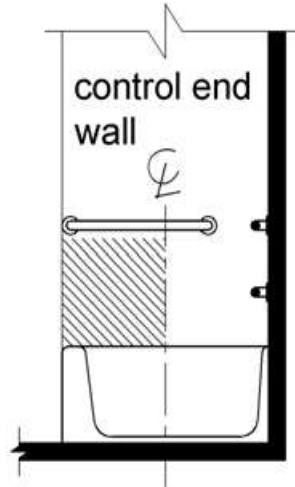

In bathtubs with permanent seats, grab bars must comply with Figure 607.4.1:

2010 ADA STANDARDS FIGURE 607.4.1

(Grab bar locations for tubs with permanent seats at head of tub)

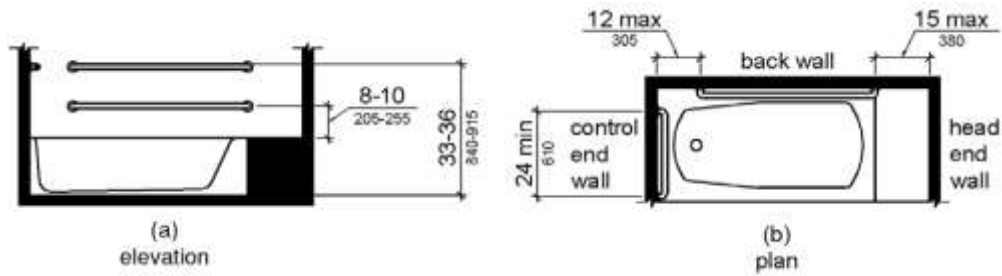

In bathtubs with removable in-tub seats, grab bars must comply with Figure 607.4.2:

2010 ADA STANDARDS FIGURE 607.4.2

(Grab bar locations for tubs with removable seats)

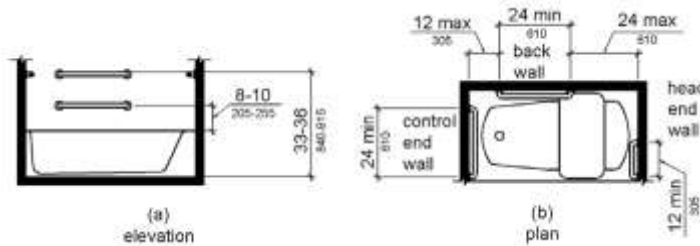

In accessible rooms where a roll-in shower is not required, it is also acceptable to provide a transfer shower. The following is a diagram of an accessible transfer shower:

2010 STANDARDS FIGURE 608.2.1

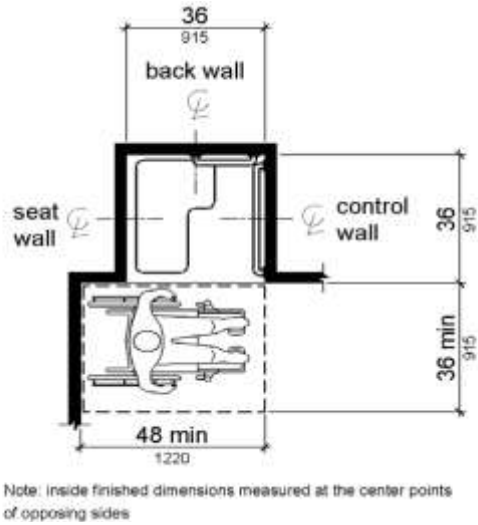

Example of an accessible transfer shower

Grab bars in transfer showers must be provided across the control wall and back wall to a point 18" from the control wall, as shown in Figure 608.3.1:

2010 STANDARDS FIGURE 608.3.1

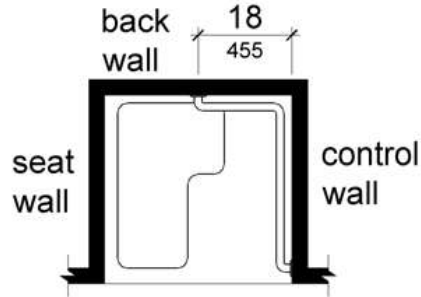

The controls, faucet, and shower spray unit in transfer showers must be installed on the side wall opposite the seat between 38" (minimum) and 48" (maximum) above the shower floor, and on the control wall no more than 15" from the centerline of the seat toward the shower opening.

2010 STANDARDS FIGURE 608.5.1

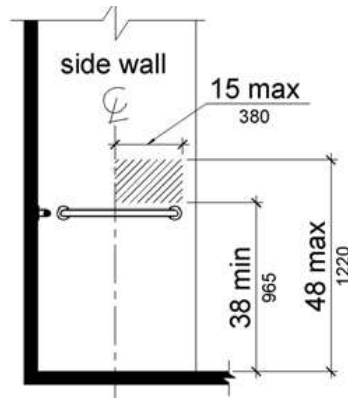

Lodging facility owners and operators should keep in mind that each one of these bathing elements has many other specific requirements for the seat, placement of grab bars, faucets, controls, and shower spray unit that should be reviewed by their attorneys, architects, or ADA consultants. The diagrams reproduced above are only to provide a general overview of these fixtures.

Technical requirements for accessible bathtubs, roll-in and transfer showers can be found in the 2010 Standards at Sections 607 and 608, respectively.

e. Accessible Rooms with Communications Features for the Deaf or Hard of Hearing

An accessible room with communications features for the deaf or hard of hearing must have:

- A visual fire alarm with a strobe, in addition to the audible alarm, that can be seen in all areas of the guest room that are not connected to any visual notification devices.
- A visual notification device that lights up when the phone rings.
- A visual notification device that lights up when the door bell is rung or when there is a door knock.
- An outlet within 4 feet of the phone to allow the guest to plug in a TTY; and
- A phone with volume control.

Under the 1991 Standards, the requirement to provide communications features can be met using a portable communications kit containing these items (*see* discussion about communications kits in Section VI.B.). The 2010 Standards explicitly state that the visual fire alarms be built-in. The 2010 Standards do not specify that notification devices for incoming telephone calls and door/knock or door bell must also be permanent. However, in connection with its discussion of pool lift requirements, DOJ has insisted that all elements in the 2010 Standards must be “fixed.”



Example of built-in visual fire alarm.

The requirements for accessible rooms with communications features can be found in the 2010 Standards at Section 806.3.

f. Accessible Rooms with Mobility and Communications Features for the Deaf or Hard of Hearing

Such a room would have all of the features discussed in the two previous sections. As previously mentioned, the 1991 Standards require all “mobility” accessible rooms to provide the communications features highlighted in section (e) above.

7. Ice and Vending Machine Areas

Ice and vending machine areas must, at a minimum, meet the following requirements in order to be accessible to a guest with a mobility disability:

- A doorway that is accessible (*see* Section IV.E.1.g.).
- A 30" x 48" clear floor space in front of the vending and ice machines; and
- An accessible route to the vending and ice machines (*see* Section IV.E.1.d.).

The 1991 Standards do not require vending machines to have controls within accessible reach ranges. However, the 2010 Standards do so require.

If an ice or vending machine area in a pre-ADA lodging facility cannot be made accessible with readily achievable measures, the facility should implement a procedure to ensure that guests who cannot access the vending area have access to ice and vending machine products (*e.g.*, assistance or in-room delivery). If some, but not all, vending areas are accessible, directional signage indicating the location of the accessible vending areas should be posted at the non-accessible vending areas, and signage with the ISA symbol should be displayed at the accessible vending areas.

8. Restaurants and Bars

a. Accessible Seating

The ADA requires restaurants and bars to have seating that is accessible to individuals who use wheelchairs. Although DOJ has made recent pronouncements that the 1991 Standards and the 2010 Standards only apply to built-in elements, the DOJ routinely applies the rules from these standards to dining tables that are not built-in. Under the 1991 Standards, if table seating is provided for guests, at least 5% (but not less than one) of the tables must be accessible. Thus, if there are thirty tables in a restaurant, at least two (2) must be accessible. If the restaurant provides both large and small tables, accessible tables of each type must be provided. If a restaurant has different seating areas that are different in ambiance or services (*e.g.*, bar area seating, dining room seating, communal seating, semi-private booths), then there must be accessible tables in each area.

This rule changes somewhat under the 2010 Standards. Under the 2010 Standards, 5% of the seating (as opposed to tables) has to be accessible. Thus, if there are 110 seats in a restaurant, six (6) must be located at accessible tables. The same principles concerning dispersion of the seating should be applied.

Under the 1991 Standards, if bar seating is provided, a 6' long portion of the bar must be no higher than 34" AFF with the required knee/toe clearance underneath so that an individual in a wheelchair can use the bar. However, the 1991 Standards allow lodging facilities to provide an

accessible table instead of the lowered bar section as long as the table is in the same area as the bar and bar service is provided at this table. The 2010 Standards do not provide this alternative.

To be considered accessible, a table must meet the following requirements:

- Be on an accessible route (*see* Section IV.E.1.d.);
- Have a top surface that is between 28” and 34” AFF; and
- Have clearance underneath that is 30” (W) x 19” (D) x 27” (H) (The 2010 Standards only require 17” (D)). (Imagine a box that has these dimensions and ask if this box can be pushed completely under the table without hitting any obstruction).

The required clearance under the table must be entirely clear space. Single pedestal tables with a base generally are not accessible because the base intrudes into the required clear space.



Example of accessible table.



Example of inaccessible table.

Both the 1991 Standards and the 2010 Standards require a 36” wide path (narrowing to 32” (W) at doorways or for distances of up to 24”) from the entrance of the restaurant to the accessible seating, and to the other amenities in the restaurant (*e.g.*, restrooms, buffet).

b. Self-Service Items

Many lodging facilities have self-service buffets or beverage stations. One of each type of self-service item, including food, beverages, napkins, plates, and utensils, must be placed within the accessible reach ranges discussed in Section IV.E.1.h. If it is not possible to arrange the buffet to have one of each self-service item within accessible reach ranges, then access can be provided through employee assistance. In any event, lodging facilities must always be prepared to provide assistance to individuals with disabilities because some may not be able to reach or locate items due to their disabilities.

9. Business Center

Self-service business centers are typically rooms with work stations, printers, and copiers. To be accessible, a business center must meet the following requirements:

- Be on an accessible route (*see* Section IV.E.1.d.);
- Have an accessible door (*see* Section IV.E.1.g.);
- Have a 36” wide path (narrowing to 32” (W) at doorways or for distances of up to 24”) to one accessible work station and one of each of the amenities provided in the room (*e.g.*, printer, fax machine, copier);
- Have an accessible work station that:
 - Has a top surface that is 28” to 34” AFF; and
 - Has clearance underneath that is 30” (W) x 19” (D) x 27” (H) (The 2010 Standards only require 17” (D)).
- One of each type of equipment whose controls and dispensing points are placed within reach range and are adjacent to a 30” x 48” clear floor space (*see* Section I.V.E.1.h.);
- If there is a card reader for entry into the room, it must be placed within accessible reach ranges (*see* Section IV.E.1.h.); and
- Provide the turning space required (*see* Section IV.E.1.f.).

10. Meeting Rooms

Meeting rooms typically have some or all of the following elements: House telephones, environmental and lighting controls, a counter for setting up materials or food and beverages, tables set up for attendees, and audio-visual equipment. The main requirements for meeting rooms are as follows:

- Be on an accessible route (*see* Section IV.E.1.d.);
- The doors to meeting rooms must be accessible (*see* Section IV.E.1.g.);
- The controls for telephones and environmental/lighting (if to be used by guests) must be placed within accessible reach ranges (*see* Section IV.E.1.h.);
- The self-service beverage and food service should be set up so that at least one of each item is located within accessible reach ranges;

- If counters are used for food and beverage service, their tops should be no higher than 34” AFF to allow guests in wheelchairs to reach over the counter for food and beverage items. If 36” (H) counters are provided, items should be placed within 10” of the edge of the counter and there must be space for a parallel approach to the counter;
- Some tables used for meeting attendees must have a top surface that is no more than 34” AFF and clearance underneath that is 30” (W) x 19” (D) x 27” (H) (The 2010 Standards only require 17” (D)). If all of the tables are not accessible, at least 5% of the tables in the room must be accessible and dispersed in various locations; and
- When planning meetings, lodging facilities should find out ahead of time whether assistive-listening devices and ramps to the stage are needed.

11. Recreational Facilities

As previously stated in Section IV.D., the 2010 Standards contain accessibility requirements for a long list of existing lodging facility recreational facilities, including fitness centers, swimming and wading pools, spas, and saunas. The 2010 Regulations require *lodging facility owners and operators to bring all of these existing recreational facilities into compliance with the 2010 Standards by March 15, 2012 (January 31, 2013 for swimming pools, spas and wading pools), if it is “readily achievable” for them to do so.* This section focuses on the recreational facilities most commonly found at places of lodging.

a. Fitness Centers

The 2010 Standards require that existing fitness centers be accessible to guests with disabilities. The general requirements are as follows:

- Be on an accessible route (*see* Section IV.E.1.d.);
- The door to the fitness center must be accessible (*see* Section IV.E.1.g.);
- There must be a clear, 36” W (minimum) route to one of *each type of* exercise machine or equipment; and
- There must be clear floor space measuring at least 30” x 48” next to one of each type of “exercise machine or equipment.” (The 2010 Standards do not define this term). The accessible route and clear floor space can overlap. The clear floor space should generally be positioned to the side

of the equipment unless the equipment can only be used while standing (e.g., ellipticals, treadmills, stair climbers). In this situation, the clear floor space can be placed at the end of the equipment.

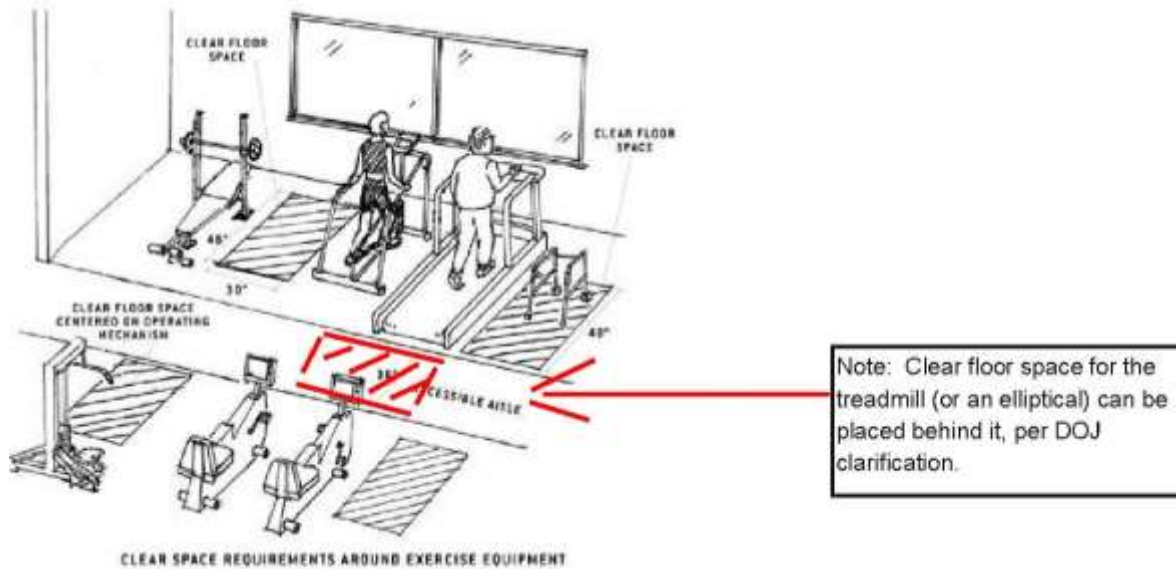

Lodging facilities should also provide access to weight racks, exercise ball storage racks, and other exercise equipment storage locations in addition to access to cardio and strength machines.

Locker room facilities serving fitness centers also must be accessible. Elements required to be accessible in a locker room include 5% of lockers, bench seating, and at least one of the following items: shower, sink, toilet, mirror, hooks, and bathroom amenities such as dispensers for soap, towels, and other products.

b. Swimming Pools, Spas, and Wading Pools

Large pools (300 or more linear feet around the pool perimeter) must have at least two accessible means of entry. The primary means of entry must be either a sloped entry into the water or a pool lift that can be independently operated by an individual with a disability. The secondary means of entry can be a pool lift, sloped entry, transfer wall, transfer system, or pool stairs.

Small pools (less than 300 linear feet around the pool perimeter) must provide one accessible means of entry which must be either a pool lift or sloped entry.

Each wave action, leisure river, sand bottom, or other type of pool where entry is limited to one area must have one accessible means of entry.

Spas must provide at least one accessible means of entry which can be a pool lift, transfer wall, or transfer system. If spas are provided in a cluster, 5% of the total—with a minimum of

one spa—per cluster must be accessible. Footrests are not required on pool lifts provided at spas. However, footrests or retractable leg supports are encouraged, especially on lifts used in larger spas where the water depth is 34” or more and there is sufficient space.

Each **wading pool** must provide at least one sloped entry into the deepest part of the pool. Other forms of entry may be provided as long as the sloped entry is provided. The sloped entries for wading pools are not required to have handrails.

The detailed technical requirements for the various types of accessible means of entry for swimming pools, spas, and wading pools can be found in the 2010 Standards at Section 1009. They are discussed generally below.

(i) **Pool Lift**

A pool lift must meet the following requirements under the 2010 Standards:

- Seat height and width (Sections 1009.2.4 and 1009.2.5);
- Footrest (Section 1009.2.6);
- Armrest (Section 1009.2.6);
- Independently operable by user (Section 1009.2.7);
- Controls and operating mechanisms (Section 1009.2.7);
- Submerged depth (Section 1009.2.8);
- Lifting capacity (Section 1009.2.9); and
- Various other space requirements relating to location of installation (Sections 1009.2.1 through 1009.2.3).

In addition to the requirements explicitly stated in the 2010 Standards, the DOJ issued a technical guidance document and a “Q & A” document on May 24, 2012, that address additional requirements for the use of pool lifts. The additional requirements are as follows:

- Pool lifts must be “fixed” unless it is not “readily achievable” to install a fixed lift. A “fixed” lift is one that is “attached to the pool deck or apron in some way.” A “portable” lift (*i.e.*, a lift that can be moved) can be a “fixed” lift if it is attached to the pool deck or apron in some way.
- If it is not “readily achievable” to install a fixed lift, a “non-fixed” lift can be used. A “non-fixed” lift is one that is “not attached in any way” to the pool deck or apron.
- The “readily achievable” analysis is “flexible” and does not require actions that are “too expensive or difficult.” While the DOJ does not

provide any concrete examples of “readily achievable” actions, it does state that the resources of a franchisor should not be considered in determining if installing a fixed lift is “readily achievable” for a franchisee.

- The DOJ will exercise its “prosecutorial discretion” to not enforce the fixed lift requirement against a lodging facility that purchased a non-fixed lift prior to March 15, 2012. To that end, the Q & A seems to suggest that the DOJ will not require lodging facilities with pre-March 15, 2012 non-fixed lifts to affix the lifts to the pool deck or apron even if it later becomes readily achievable to do so.
- Pool lifts must be in position, ready for use, and fully operational during pool or spa hours. This has caused much dismay among lodging facility owners and operators who fear that children and others will misuse the lift and become injured, particularly at unattended pools. The Q & A addresses this concern by stating that legitimate safety concerns are a part of the “readily achievable” analysis, but cautions that such concerns cannot be based on “speculation.” This seems to leave open the possibility that if a lodging facility has prior experience with children or other individuals playing on or misusing a lift, the lodging facility may have a legitimate basis for storing the lift away from the pool deck or apron and only bringing it out upon request.
- A lift cannot serve more than one pool or spa even if they are adjacent to each other. If it is not “readily achievable” for a lodging facility to have lifts at each pool and spa, the facility does not have to close any pool or spa that does not have a lift. However, the facility will have to purchase an additional lift(s) for each pool and spa when it becomes “readily achievable” to do so.
- Employees must be trained on how to use and maintain the lift.
- Pool lift batteries must be fully charged at all times when the pool or spa is open.

Copies of the DOJ’s May 24, 2012 technical guidance document and Q & A can be found at: http://www.ada.gov/pools_2010.pdf and http://www.ada.gov/qa_existingpools_titleIII.htm.

(ii) Sloped Entry

A sloped entry must meet the following requirements under the 2010 Standards:

- Be at least 36” wide (Section 1009.3.1);
- Have a maximum slope of 8.33% (Section 1009.3.1);

- Extend 24"-30" below the stationary water level (Section 1009.3.2);
- Have top and bottom landings if the running slope is greater than 5% (Section 1009.3.1); and
- Have handrails on both sides (except in wading pools) (Section 1009.3.3).

DIAGRAM AND PHOTO OF SLOPED ENTRY:

2010 STANDARDS FIGURE 1009.3.2

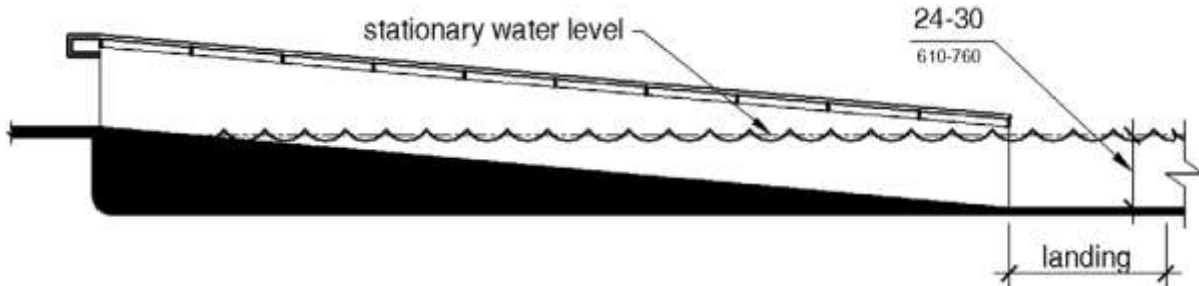

(iii) Transfer Wall

A transfer wall is a wall along an accessible route that allows an individual with a disability to leave his/her wheelchair or other mobility device and transfer onto the wall and then into a pool or spa. A diagram of a compliant transfer wall is provided below.

2010 STANDARDS FIGURE 1009.4.2

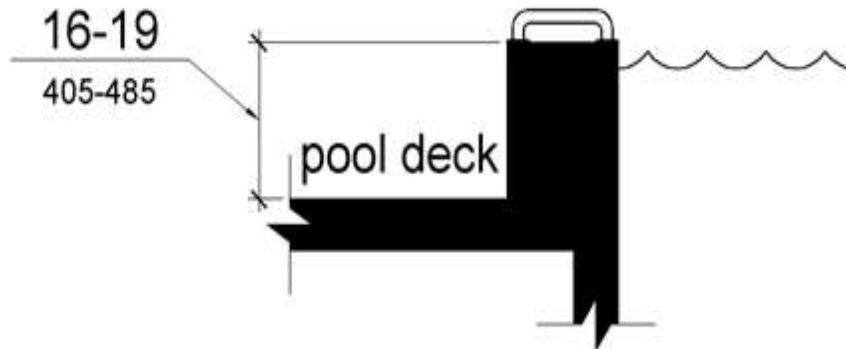

The transfer wall must meet the following requirements under the 2010 Standards:

- Clear deck space (Section 1009.4.1);

- Height, width, and length of wall (Sections 1009.4.2 and 1009.4.3);
- Surface (Section 1009.4.4) and
- Grab bars (Section 1009.4.5).

(iv) Transfer Systems

A transfer system consists of a transfer platform and a series of transfer steps that descend into the water. Users transfer from their wheelchair or other mobility device to the transfer platform and continue transferring into the water, step by step. A diagram of a compliant transfer system is provided below.

2010 STANDARDS FIGURE 1009.5.4

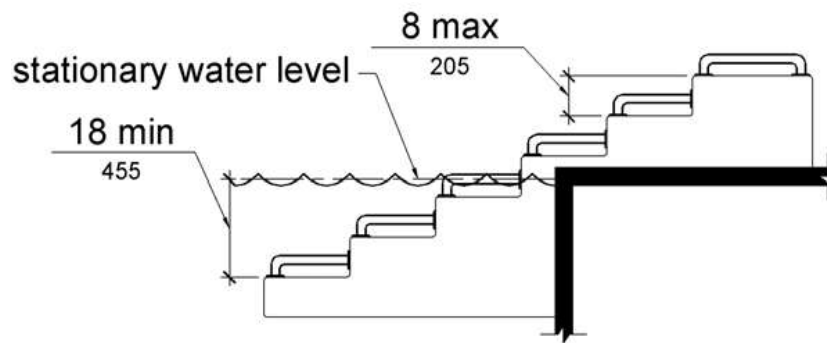

The transfer system must meet the following requirements under the 2010 Standards:

- Platform height, depth, and width (Sections 1009.5.1 and 1009.5.3);
- Transfer space (Section 1009.5.2);
- Transfer steps (Sections 1009.5.4 and 1009.5.6);
- Surface (Section 1009.5.5); and
- Grab bars (Section 1009.5.7).

(v) Pool Stairs

Accessible pool stairs begin at the pool deck level and descend into the water.

The pool stairs must meet the following requirements under the 2010 Standards:

- Treads and risers (Sections 504.2 through 504.5); and
- Handrails (Section 1009.6.2).

c. Steam Rooms and Saunas

The 2010 Standards require that one of each type of sauna and steam room, or 5%, whichever is greater, at each lodging facility must comply with the following requirements:

- Be on an accessible route (*see* Section IV.E.1.d.);
- The door to the steam room or sauna must be accessible (*see* Section IV.E.1.g.);
- There must be turning space (*see* Section V.E.1.f.);
- There must be a 30" x 48" clear floor space outside of the door swing;
- If seating is provided, the bench must have a seat that is 17"-19" AFF, a minimum of 42" long and 20"-24" deep, and can hold at least 250 pounds;
- There must be a 30" x 48" clear floor space at the short end of the bench (with the 48" side being adjacent to the short end); and
- The bench must be mounted on a wall or have back support that is at least 42" long that extends from a point no more than 2" above the seat surface to a point at least 18" above the seat surface. Back support must be no more than 2½" from the rear edge of the seat measured horizontally.

These requirements can be found in the 2010 Standards at Section 612.

V. REASONABLE MODIFICATION OF POLICIES, PRACTICES, AND PROCEDURES

A. Common Modifications

Lodging facilities, like most businesses, have policies, practices, and procedures that keep them running smoothly. However, sometimes those policies, practices, and procedures need to be modified to ensure that an individual with a disability has access to the facility's goods, services, and/or accommodations. Thus, the ADA requires lodging facilities to make reasonable modifications to their policies, practices, and procedures—at no additional charge—where necessary to ensure access by individuals with disabilities *unless the modifications would fundamentally alter the nature of the goods, services, or amenities provided by the lodging facility or pose a direct threat to the health and safety of others.*

Most reasonable modifications involve only minor adjustments to policies and procedures, or the provision of some additional services at no additional charge. Here are some examples of actions that may be required:

- Accepting an alternative form of government-issued identification from a guest who may not have a driver's license due to his/her disability;

- Providing assistance with luggage;
- Removing or relocating furniture in a guest room to create more wheelchair maneuvering space;
- Removing a bed frame to lower a bed if necessary for a guest in a wheelchair to transfer onto the bed;
- Substituting ingredients for guests with food allergies;
- Providing assistance in retrieving items in a store;
- Locating or retrieving food items from the lodging facility restaurant's buffet;
- Locating or retrieving merchandise in a retail store;
- Setting up a self-service buffet so that one of each type of item and utensil is within accessible reach ranges;
- Cutting food into smaller pieces;
- Providing verbal directions or assistance in locating certain features of a guest room or in common areas (*e.g.*, the location and items of furniture in the room, the location and operation of the thermostat or in-room safe, and the location of the nearest emergency exit);
- Parking a van used by an individual with a disability in front of the lodging facility or an alternate convenient location when there is no van accessible parking in the garage;
- At a valet-only parking facility, allowing a guest to self-park a vehicle with hand controls because the valet service does not handle cars with hand controls;
- If the lodging facility provides complimentary transportation and the vehicles are not accessible, arranging and paying for equivalent accessible transportation provided by a third-party service (*see* Section VIII regarding transportation); and
- Setting up space for events in a manner that provides access for individuals with disabilities, such as ensuring that there is accessible seating and an accessible route to key areas of the event venue such as raised platforms.

These are only examples of the types of modifications that a lodging facility might have to provide. The key to ADA compliance is to listen to the guest and meaningfully consider all requests.

The more significant “reasonable modifications” that are required in the lodging facility setting are discussed in greater detail below.

B. Reservations and the Proper Assignment of Accessible Rooms

According to the DOJ, travelers with disabilities frequently complain about: (1) the extra time and effort that they must expend to reserve accessible rooms; (2) the lack of information about accessibility features in a lodging facility’s common areas or in accessible guest rooms; and (3) the unavailability of reserved accessible rooms upon check-in. To address these issues, the DOJ created new rules in the 2010 Regulations for lodging facility reservations. Effective March 15, 2012, an entity that owns, operates, or leases a place of lodging must, for reservations made by any means (including by telephone, via website, in person, or through a third-party reservations service):

1. Modify its policies, practices, or procedures to ensure that individuals with disabilities can make reservations for accessible guest rooms during the same hours and in the same manner as individuals who do not need accessible rooms;
2. Identify and describe accessible features in the lodging facility and guest rooms offered through its reservations service in enough detail to reasonably permit individuals with disabilities to independently assess whether a given facility or guest room meets his or her accessibility needs;
3. Ensure that accessible guest rooms are held for use by individuals with disabilities until all other guest rooms of that type have been rented and the accessible room requested is the only remaining room of that type;
4. Reserve, upon request, accessible guest rooms or specific types of guest rooms and ensure that the guest rooms requested are blocked and removed from all reservations systems; and
5. Guarantee that the specific accessible guest room reserved through its reservations service is held for the reserving guest, regardless of whether a specific room is held in response to reservations made by others.

The third, fourth, and fifth requirements above do not apply to reservations for individual guest rooms or units not owned or substantially controlled by the entity that owns, leases, or operates the overall lodging facility.

The first and second requirements are designed to ensure that individuals with disabilities can reserve accessible rooms with the same level of convenience as individuals who reserve non-accessible rooms. The accessible room options available to a guest must be displayed with the information that is necessary for the guest to decide whether the room meets his or her needs. The DOJ stated in its commentary to the regulations that, at a minimum, a reservations system must, for each accessible room, provide information about the room type, number of beds, type of accessible bathing fixture, and visual alarms and notification devices in the room. In addition, each lodging facility must provide accessibility information about the common areas. If a hotel

cannot declare that it is accessible, then information about accessible entrances to the hotel, the path of travel to guest check-in and other essential services, and the accessible route to the accessible room or rooms must be provided, including “information about important features that do not comply with the 1991 Standards.” As examples, DOJ specifically called out inaccessible door widths in accessible rooms and alternate locations for check in or concierge services when the main locations are not accessible.

The third requirement ensures that accessible rooms are not reserved for, or assigned to, guests who do not need them until they are the only remaining rooms of their type. For example, if there are 10 King standard rooms available and two (2) of these are accessible, the eight (8) non-accessible rooms should be sold or assigned before the two (2) accessible rooms are sold or assigned, unless the accessible rooms are specifically requested by a guest. Once the accessible rooms are the only rooms that are left of their type, they can be sold or assigned to any guest. Lodging facilities must train their front desk and reservations employees on this requirement.

The fourth and fifth requirements are designed to ensure that accessible rooms reserved for guests with disabilities will be available when the guests check-in. Lodging facilities must make sure that accessible rooms that are reserved are removed from the available inventory and that they are assigned to the guests who reserved them.

If a lodging facility has taken steps to comply with the fourth and fifth requirements described above, the accessible rooms that guests have reserved should be available upon their arrival. However, front desk employees should also have a list of all of the accessible rooms in the lodging facility and information about the accessibility features contained in each room in order to properly assign rooms and answer questions about the rooms.

Compliance with these requirements will require changes to reservations systems as well as practices by reservations agents and employees at lodging facilities.

C. Service Animals

The ADA has always required lodging facility owners and operators to allow individuals with disabilities to be accompanied by a service animal in all areas of a facility that are open to other guests. The 1991 Regulations defined a service animal as “any guide dog, signal dog, *or other animal* individually trained to do work or perform tasks for the benefit of an individual with a disability.” The 2010 Regulations changed the rules regarding service animals. Effective March 15, 2011:

- Only dogs qualify as service animals under the ADA (*but see* discussion about miniature horses below).
- Pets and animals that only provide emotional support, well-being, comfort or companionship (as opposed to animals that perform actual work or tasks related to an individual’s psychological disability) are *not* service animals.

Lodging facility owners and operators should be aware that certain states may allow animals other than dogs to be service animals, and some may even consider emotional support animals to be service animals. Some states also extend protections to service animals in training and their trainers. Therefore, service animal policies must also take into account state and local laws. Every lodging facility should have a written service animal policy that is distributed to all employees who interact with the public.

The 2010 Regulations have a new, separate provision about miniature horses that are individually trained to do work or perform tasks for individuals with disabilities. Miniature horses generally range in height from 24” to 34” measured to the shoulders and generally weigh between 70 and 100 pounds. Entities covered by the ADA must modify their policies to permit miniature horses to accompany individuals with disabilities where reasonable. The 2010 Regulations set out four assessment factors to assist entities in determining whether miniature horses can be accommodated in their facilities. The assessment factors are:

- Whether the miniature horse is housebroken;
- Whether the miniature horse is under the individual’s control;
- Whether the facility can accommodate the miniature horse’s type, size, and weight; and
- Whether the miniature horse’s presence will compromise legitimate safety requirements necessary for safe operation of the facility.

As a practical matter, miniature horses should be treated the same as dogs that function as service animals.

The DOJ posted a user-friendly document on its website that explains the new service animal rules. A copy of that guidance can be found at: http://www.ada.gov/service_animals_2010.htm.

Here are some specific service animal rules from the DOJ guidance:

- Service animals must be harnessed, leashed, or tethered, unless these devices interfere with the service animal’s work or the individual’s disability prevents using these devices. In that case, the individual must maintain control of the animal through voice, signal, or other effective controls.
- When it is not obvious what service a dog or miniature horse provides, only limited inquiries are allowed. Employees may ask two questions:
 - Is the animal required because of a disability?
 - What work or task has the animal been trained to perform?

- Lodging facility employees cannot ask about the individual's disability, require medical documentation, require a special identification card or training documentation for the service animal, or ask that the animal demonstrate its ability to perform the work or task.
- Allergies to, and fear of, animals are not valid reasons for denying access or refusing service to individuals using service animals. When someone who is allergic to animals must spend time in the same room or facility as an individual who uses a service animal, they both should be accommodated by assigning them, if possible, to different locations within the room or facility.
- An individual with a disability cannot be asked to remove his or her service animal from the premises unless: (1) the animal is out of control and the individual does not take effective action to control it; or (2) the animal is not housebroken. When there is a legitimate reason to ask that a service animal be removed, the lodging facility must offer the individual with the disability the opportunity to obtain goods or services without the animal's presence.
- Establishments that sell or prepare food must allow service animals in public areas even if state or local health codes prohibit animals on the premises.
- Individuals with disabilities who use service animals cannot be isolated from or treated less favorably than other guests, or charged fees that are not charged to other guests without animals. In addition, if a lodging facility requires a deposit or fee to be paid by guests with pets, it must waive the charge for service animals.
- If a lodging facility normally charges guests for damage that they cause, a guest with a disability may also be charged for damage caused by himself/herself or his/her service animal.
- The lodging facility is not required to provide care or food for a service animal.

One question that has come up often is whether a lodging facility must allow service animals to swim in swimming pools with individuals with disabilities. During an AH&LA-sponsored webinar in September 2010, the DOJ provided informal guidance that this is not required because it would fundamentally alter the nature of the swimming pool experience.

D. Power Mobility Devices

The 1991 Regulations required lodging facilities to make reasonable modifications to their policies, practices, and procedures to allow individuals with mobility disabilities to use

traditional mobility devices such as wheelchairs, walkers, and canes in all areas of a facility where guests and visitors usually go.

Under the 2010 Regulations, lodging facilities still must permit the use of traditional mobility devices. In addition, lodging facilities must permit individuals with mobility disabilities to use a new category of devices referred to as “other power-driven mobility devices” (OPMDs). OPMDs include a range of devices not specifically designed for individuals with mobility impairments but which are often used by individuals with disabilities as their mobility device of choice, such as Segways© and golf carts.

Lodging facilities may not inquire about the nature of an individual’s disability in connection with a request to use an OPMD. *If the reason for an individual’s use of an OPMD is not obvious, lodging facilities may ask whether the OPMD is required because of a mobility disability. Lodging facilities may also request the individual to provide a valid, state-issued disability parking placard or card, or state-issued proof of disability.*

Lodging facilities may restrict the use of OPMDs under certain circumstances. The DOJ has stated that a lodging facility can consider the following criteria in making this determination:

- The type, size, weight, dimensions, and speed of the device;
- The facility’s volume of pedestrian traffic (which may vary at different times of the day, week, month, or year);
- The facility’s design and operational characteristics, such as its square footage, whether it is indoors or outdoors, its placement of stationery equipment or devices or furniture, and whether it has storage space for the device if requested by the customer;
- Whether legitimate safety standards can be established to permit the safe operation of the device; and
- Whether use of the device creates a substantial risk of serious harm to the environment or natural or cultural resources, or poses a conflict with Federal land management laws and regulations.

Lodging owners and operators may want to consider developing an OPMD policy. The DOJ has not issued any guidance on the drafting of an OPMD policy. However, the General Services Administration’s interim policy on the use of Segways© may be a helpful resource in crafting a policy: http://www.gsa.gov/graphics/pbs/Interim_Segway_Policy_121007.pdf.

E. Emergency Procedures

Advance planning, development of emergency procedures, and consistent, ongoing training are critical to ensure the safety of guests with disabilities in the event of an emergency. In the event of an emergency, guests with disabilities need to know:

- The emergency evacuation procedures for the lodging facility;
- Where the accessible fire exits and pathways are located throughout the lodging facility;
- In case of an evacuation, where the designated outdoor meeting points are located;
- The location of visual and audible fire and smoke alarms throughout the lodging facility; and
- The lodging facility's ability to notify guests with disabilities of an emergency through various methods such as TTY, telephone calls, text messaging, e-mail, direct door-to-door contact, or text and audio alerts in all in-house closed-circuit TV announcements.

Lodging facility employees should be able to perform the following tasks in the event of an emergency:

- Provide the room numbers of guests with disabilities to emergency responders;
- Determine if a guest with a disability has any special equipment needs related to emergency notification;
- Provide teletypewriters or text telephones (TTYs), telecommunication devices for the deaf (TDDs), flashers, and other equipment to guests with disabilities who are deaf or hard of hearing;
- Ensure that flashers and other accessible equipment provided at the lodging facility are tied to, or triggered by, the emergency alarm;
- Notify guests with disabilities where the emergency exits are located in the lodging facility; and
- Evacuate guests with visual, mobility, auditory, or other disabilities, including a two-person carry if necessary.

VI. AUXILIARY AIDS AND SERVICES

A. Effective Communication Requirements

Guests who are blind or have low vision, are deaf or hard of hearing, or have speech disabilities use different methods of communicating than other guests. The ADA requires lodging facilities to ensure that their communications with these individuals are effective so that they have an equal opportunity to enjoy the goods, services, accommodations, and amenities that the lodging facility offers to its guests. The following general rules apply to such communications:

- The type of auxiliary aid or service necessary to ensure effective communication will vary in accordance with: (1) the individual's usual mode of communication; (2) the nature, length, and complexity of the communication involved; and (3) the context in which the communication is taking place.
- If an individual with a disability requests an auxiliary aid or service, the lodging facility must consult with the individual to determine what type of auxiliary aid is needed to ensure effective communication. However, the ultimate decision as to what measures to take rests with the lodging facility, provided that the method chosen results in effective communication.
- In order to be effective, auxiliary aids and services must be provided in accessible formats, in a timely manner, and in such a way as to protect the privacy and independence of the individual with a disability.
- If the situation calls for an interpreter, lodging facilities may not rely on friends or family members to interpret, unless the individual with a disability wants a friend or family member to interpret, and the friend or family member consents.
- Under no circumstances should a minor child be used as an interpreter, except in an emergency involving an imminent threat to the safety or welfare of an individual or the public and there is no other interpreter available.
- The lodging facility must accept calls made via relay service and handle them in the same manner as other telephone calls. A relay call is one that is made by an individual who has a speech or hearing disability to a relay operator with whom the caller can communicate by using sign language or typing. The relay operator then calls the business and relays the caller's words to the business.

Auxiliary aids and services are devices and methods that facilitate effective communication for individuals with vision, hearing, or speech disabilities. The ADA requires lodging facilities to provide these devices and services *free of charge* unless doing so would either fundamentally alter the nature of the goods and services provided, or cause an undue burden. The following sections describe the various auxiliary aids and services that could be used to communicate with individuals with various types of disabilities.

1. Communicating with Guests Who are Blind or Have Low Vision

- Relatively uncomplicated documents such as documentation provided at check-in, directories of events, and menus can be read out loud. Always consider privacy concerns when communicating private information, including personal and financial facts.

- More complicated documents such as event contracts can be provided in large print, Braille, electronic, or audio formats.
- Forms or paperwork can be completed for the guest by lodging facility employees.
- Documents can be provided to the guest in an electronic format which can be used with screen readers and/or magnified for reading.

2. Communicating with Guests Who are Deaf or Hard of Hearing

- Lodging facilities must accept calls made by telecommunications relay services (*see* explanation below).
- Lodging facility employees may point to written material to communicate information.
- Lodging facility employees may exchange written notes with a guest who is deaf or hard of hearing.
- Lodging facility employees may use facial expressions or physical gestures that illustrate information.
- For complicated communications such as event planning, it likely will be necessary to use an auxiliary device or service such as a text telephone, telecommunications relay service, real-time captioning, a qualified interpreter, or a video remote interpreting service (VRI). Lodging facility owners and operators should familiarize themselves with the options and agencies that provide interpreting and/or captioning services in their geographic locations. The DOJ's ADA Information Line is available to identify such service providers.
 - *Teletypewriter or Text Telephone (TTY) or Telecommunication Device for the Deaf (TDD).* TTY or TDD permits people who are deaf, hard of hearing, or have a speech disability to communicate via telephone with another individual or business. The deaf person uses a TTY/TDD device to call a dedicated TTY/TDD line that has a device on the receiving end. Since most lodging facilities will not have dedicated a TTY/TDD number, individuals who are deaf likely will call a telecommunications relay service as explained below.
 - *Telecommunication Relay Services (TRS).* A TRS call is a call that is made by an individual who has a speech or hearing disability to a relay operator (communication assistant). The person with a disability uses a TTY/TDD, computer keyboard, video camera, or other input device to call or connect with the relay center, and

provides the communications assistant with the lodging facility's phone number. The communication assistant then calls the lodging facility and communicates with the lodging facility employee in a traditional voice. The communications assistant serves as the link for the call, relaying messages between the caller and lodging facility. Examples of TRS include telephone/TTY-based relay services, internet-based relay services (IP Relay), and video-based relay services (VRS). If the lodging facility wants to call a guest who uses TRS, all the lodging facility employee will need to do (in most cases) is call the phone number that the guest provided. If the provided number results in a mechanical sound, the lodging facility employee should hang up, dial 711 for a relay service, and have the answering communication assistant dial the number the guest provided. If the communication assistant informs the lodging facility employee that the phone number is not a TTY line, then the guest is likely using IP Relay or VRS, in which case the lodging facility employee should contact an IP Relay or VRS provider to place the call.

- *Qualified Interpreter and Video Remote Interpreting Service (VRI).* Qualified interpreters include sign language interpreters, oral transliterators, and cued-language transliterators. Qualified interpreters can be provided in-person or by VRI. VRI is a service in which a qualified interpreter off site interprets both received and expressed communications using any specialized vocabulary by video. Lodging facility owners and operators should confirm that the VRI service provider offers: (1) real time full motion and audio with high quality images; (2) a clear video image that displays the interpreter and guest's face, arms, hands, and fingers; and (3) clear and audible voice transmission. If a lodging facility decides to employ a VRI service, lodging facility employees must know how to set up and operate VRI technology.
- *Communication Access Real-Time Translation or Computer-Aided Real-Time Captioning (CART).* CART is a computer software program that provides a written transcript of spoken words. CART translates the spoken word into the written word almost as quickly as people can speak. CART displays text on a laptop computer, monitor or large screen, depending on the situation.

3. Communicating with Guests who have Speech Disabilities

- Lodging facilities must accept calls made by TRS.
- Lodging facility employees may exchange notes with the guest.

- Lodging facility employees may read words, letters, or pictures displayed on the guest's communication board. A communication board allows the person with a disability to point to different graphics in order to form sentences.
- Lodging facility employees may listen to a guest's communication device that relays the guest's words in a computerized voice.
- For more extensive or complicated transactions, lodging facility employees should use TRS or TTY.

B. Communication Kits and TTYs

As discussed in Section IV.E.6, lodging facilities are required to have a certain number of accessible rooms that have communications features for guests who are deaf or hard of hearing. In many lodging facilities, these features will be permanent features of a room. But if they are not, the features must be supplied as part of a portable communications kit. The kits usually come in a suitcase containing the following items:

- Visual notification devices that flash when the telephone or doorbell rings, or when someone knocks on the door.
- A visual alarm that flashes when the building's fire alarm goes off.

The kits usually also have a vibrating disk that can be placed under a pillow to alert a sleeping guest about an incoming call or doorbell.

Some kits have a TTY. Neither the 1991 Standards nor the 2010 Standards specify how many TTYs are needed, but lodging facilities must have enough TTYs to meet the demands of guests who need to make calls from their rooms or from public pay phones. Thus, even if a lodging facility's communications features are built-in, the facility still must have TTYs on hand. In addition, a facility's PBX or front desk must have a TTY to receive internal calls from guests who use TTYs to make phone calls. External calls can be handled using TRS.

Front desk and engineering employees should be familiar with the different types of communication equipment that are available for guests with disabilities, where the communication equipment is kept, and how to operate the equipment. Lodging facilities should have procedures in place to ensure that communications kits are promptly set up for use by guests upon request.

C. Closed Captioning of TVs

Closed captioning allows individuals who are deaf or hard of hearing to have access to television programming by displaying the audio portion of a television program as text on the television screen. If a guest with a disability reserves a room with a television that does not have built-in closed captioning that can be activated, the ADA requires that the lodging facility

provide a closed caption decoder to the guest, at no cost, upon request. Televisions in common areas must have closed captioning that can be turned on upon request.

D. Automated Teller Machines (ATMs)

The 1991 Standards prescribe specific standards for ATMs to ensure physical access to these machines by individuals with mobility disabilities, but do not contain specific requirements about the features that they must have to be accessible to individuals who are blind. The 2010 Standards set forth new and very specific communications requirements to ensure that individuals who are blind can use the ATM. For example, it includes requirements for audio-guided transactions, tactile keypads, and display screens. Instead of exempting existing ATMs from these new requirements, the DOJ is requiring that existing ATMs be brought into compliance with these communications requirements by March 15, 2012. Lodging facilities should confirm with their ATM vendors that the ATMs in their facilities will comply with these new requirements.

The 2010 Standards also lowers the maximum side reach range for ATM controls and dispensing points. However, existing ATMs that comply with the 1991 Standards' reach ranges as of March 15, 2012, are in a safe harbor and do not need to be changed.

The new ATM requirements can be found in the 2010 Standards at Section 707.

E. Websites and Self-Service Equipment

The DOJ started the process of issuing regulations specifying the technical standards that must be met for websites or self-service equipment of public accommodations not already addressed by the 2010 Standards on July 26, 2012. However, no rule has actually been proposed as of August 2012. Even in the absence of enforceable standards, however, DOJ has made recent statements indicating its position that websites and self-service equipment must be accessible. Moreover, private litigants and advocacy groups have threatened and/or brought lawsuits alleging that a public accommodation's website or self-service equipment is not accessible and violates the ADA and state non-discrimination laws. Thus, lodging facility owners and operators should consider these issues and incorporate accessibility into their website development and equipment purchasing plans. The website accessibility standard under consideration by the DOJ is Web Content Accessibility Guidelines (WCAG) 2.0 AA. More information about this standard can be found at <http://www.w3.org/TR/WCAG/>.

VII. MAINTENANCE OF ACCESSIBLE FEATURES

The ADA requires that lodging owners and operators maintain the accessible features of their lodging facilities. To that end, owners and operators must ensure that:

- Exterior accessible routes and accessible parking access aisles are unobstructed at all times. Consider where cleaning and maintenance crews tend to pile snow, gravel, mulch, or equipment when working outside;

- Interior accessible routes are not narrowed or blocked by items such as furniture, trash receptacles, cleanings signs or supplies, or potted plants. These items should not be placed in front of the elevator call button;
- Housekeeping employees are trained to place items such as television remote controls and adjustable shower heads no higher than 48” AFF;
- The lowered accessible counter at the front desk is not cluttered with displays, flowers, paperwork, or other items;
- The TTY at the front desk and the hotel’s portable communications kits containing visual fire alarms and communication devices are in good working condition; and
- Wheelchair and pool lifts are in good working condition and ready for use by individuals with disabilities.

VIII. TRANSPORTATION

The 1991 Regulations and the 2010 Regulations both impose certain requirements on lodging facilities that provide transportation services to guests either on a fixed schedule (“Fixed Route System”) or when requested by guests (“Demand Responsive System”).

Existing Vehicles: Lodging facilities have an obligation to remove barriers in existing vehicles if it is readily achievable to do so. However, this obligation does not require the retrofitting of any vehicles with a hydraulic or other lift.

Newly-Acquired Vehicles: The requirements for newly acquired vehicles are as follows:

- **Fixed Route System: Vehicle Capacity Over 16:**¹² The vehicle must be readily accessible to, and usable by, individuals with disabilities, including individuals who use wheelchairs.
- **Fixed Route System: Vehicle Capacity of 16 or Fewer:** The vehicle must be readily accessible to, and usable by, individuals with disabilities, including individuals who use wheelchairs, unless the fixed route system, when viewed in its entirety, meets the standard for equivalent service (defined below).
- **Demand Responsive System, Vehicle Capacity Over 16:** The vehicle must be readily accessible to, and usable by, individuals with disabilities, including individuals who use wheelchairs, unless the system, when viewed in its entirety, meets the standard for equivalent service.

¹² This number includes the driver.

- **Demand Responsive System, Vehicle Capacity of 16 or Fewer:** The entity is not specifically required to ensure that new vehicles with seating capacity of 16 or fewer are accessible to individuals with wheelchairs. These entities are required to ensure that their systems, when viewed in their entirety, meet the equivalent service requirements regardless of whether the entities purchase a new vehicle.

A fixed route or demand responsive system, when viewed in its entirety, is deemed to provide equivalent service if the service available to individuals with disabilities (including individuals who use wheelchairs) is provided in the most integrated setting appropriate to the needs of the individual and is equivalent to the service provided to other individuals with respect to the following service characteristics:

- Schedules/headways (if the system is fixed route);
- Response time (if the system is demand responsive);
- Fares;
- Geographic area of service;
- Hours and days of service;
- Availability of information;
- Reservations capability (if demand responsive system);
- Any constraints on capacity or service availability; and
- Restriction priorities based on trip purpose (if demand responsive system).

IX. DISABILITY ETIQUETTE

In addition to the legal obligations discussed in this guide, it is important for lodging facility employees to know how to interact with individuals with disabilities. The following are some useful tips:

- When referring to an individual with a disability, use “people first” language. For example, it is better to say “an individual with a disability” rather than a “disabled person.” The term “handicapped” should never be used.
- Interact directly with the individual with a disability, not with an interpreter or others who may be accompanying the individual.
- It is appropriate to offer assistance to an individual with a disability, but do not assume that assistance is desired or required.

- When speaking with an individual who is blind or has low vision, identify yourself and others present, use verbal cues, and do not shout or over-enunciate.
- When speaking with an individual who is deaf or hard of hearing, determine if the individual reads lips. If so, face the individual, speak clearly, do not cover your mouth or chew gum, and do not turn away while speaking. It is not necessary to speak loudly or over-enunciate.
- When speaking with an individual who has a speech disability, do not assume that he/she has a mental impairment. It is not necessary to speak slowly.
- Never touch a person with a disability or their mobility device.
- When approaching a person who is blind, identify yourself and your role, if appropriate. You can also offer the person your arm if the person needs to be guided to a specific location.
- Never touch or play with a service animal.
- Count out change for a customer who is blind.

X. CALIFORNIA LODGING FACILITIES

A. The Unruh Civil Rights Act and the Disabled Persons Act

The Unruh Civil Rights Act (California Civil Code Section 51 *et seq.*) (“Unruh Act”) prohibits businesses from discriminating against any individual on the basis of disability. The Disabled Persons Act (California Civil Code sections 54 and 54.1) (“DPA”) generally guarantees individuals with disabilities the right to full and equal access to places of public accommodation. The Unruh Act and the DPA provide authority for enforcing California’s accessibility code which is set forth in Title 24 of the California Code of Regulations (“Title 24”). A violation of the ADA is also a violation of these two statutes.

Unlike the ADA, the Unruh Act and the DPA provide for recovery of monetary damages in addition to injunctive relief. The Unruh Act authorizes a plaintiff to recover *minimum* statutory monetary damages of \$4,000 per violation of California’s accessibility requirements and the ADA (as incorporated into California accessibility law).

The availability of minimum statutory damages has led to abusive litigation in California by serial plaintiffs against lodging facilities and other public accommodations. In 2008, the California legislature enacted significant amendments to the Unruh Act and the DPA. The amendments, effective January 1, 2009, provide lodging facilities and other public accommodations with mechanisms to reduce their exposure to disability access litigation, and furnish new defenses to claims for damages and attorneys’ fees. As amended, the Unruh Act and the DPA:

- Provide procedures for public accommodations to voluntarily have their facilities inspected by a Certified Access Consultant (“CASp”) and certified by the State as compliant with accessibility standards.
- Give “qualified defendants” (*i.e.*, those whose facilities have been inspected by a CASp) the right to receive a 90-day stay of proceedings and an early settlement conference in cases brought in state court.
- Limit damages recoveries to plaintiffs who personally encounter an access violation or who were deterred from accessing a public accommodation on a particular occasion(s).
- Limit statutory damages to one assessment per occasion of access denial rather than per access barrier.
- Allow courts to consider settlement offers when determining attorneys’ fees awards.

B. Differences Between Title 24 and the ADA Standards

Title 24 contains different or more stringent requirements than the ADA standards for many elements, making the construction and renovation of California lodging facilities even more complex. A few examples of such elements commonly found in lodging facilities include the following:¹³

- **Restroom Signage:** The door-mounted signage at men's restroom facilities must have a raised equilateral triangle centered horizontally on the door at 60" AFF (measured to the center of the triangle). The triangle must be 1/4" thick with edges that are 12" long, and contrast with the door (either light on a dark background or dark on a light background). (24 CCR 1115B.6.1)
- The door-mounted signage at women's restroom facilities must have a raised circle centered horizontally on the door at 60" AFF (measured to the center of the circle). The circle must be 1/4" thick, 12" in diameter, and contrast with the door (either light on a dark background or dark on a light background). (24 CCR 1115B.6.2)
- The door-mounted signage at unisex restroom facilities must have a raised circle centered horizontally on the door at 60" AFF (measured to the center of the circle) that is 1/4" thick, 12" in diameter, with a 1/4" thick equilateral triangle superimposed within the circle. The triangle must contrast with the circle, and the circle must contrast with the door (either

¹³ The requirements discussed above are from the 2010 California Building Code, Title 24, Part 2 (including Errata/Supplement through January 1, 2011).

light on a dark background or dark on a light background). (Title 24 Section 1115B.6.3)

- **Accessible routes:** Accessible routes can consist of sidewalks, ramps, curb ramps, hallways, and elevators. Under the ADA, an accessible route must be at least 36” wide, narrowing to 32” at doorways or for up to a 24” distance (2010 Standards Section 403.5.1). Under Title 24, accessible routes generally must be at least 36” wide. However, there are several exceptions to the general rule that require widths in excess of 36”, including sidewalks, curb ramps, corridors, and hallways. (24 CCR 1114B.1.2, 1127B.5, 1133B.3.2, 1133B.5.2, and 1133B.7.1).
- **Ramp landings:** Accessible ramps must have landings at the top and bottom of each ramp run and at each change of direction. Under the ADA, ramp landings must be at least 60” long in the direction of the ramp run (2010 Standards Sections 405.7.3 and 405.7.4). Under Title 24, bottom ramp landings must be at least 72” long in the direction of the ramp run (24 CCR 1133B.5.4.6).
- **Signage at accessible parking spaces:** The ADA requires all standard accessible parking spaces to be identified with a vertically mounted sign that includes the ISA. The signage at van accessible parking spaces must include the ISA and the designation “van accessible.” Signs must be mounted at 60” AFF to the bottom of the sign (2010 Standards Section 502.6). Under Title 24, accessible parking space signage must measure at least 70 square inches, be posted at least 80” above the ground (measured to the bottom of the sign) when posted in a path of travel, and have additional language below the ISA stating “Minimum Fine \$250.00” (24 CCR 1129B.4). Title 24 requires an additional sign be posted at the entrance to the parking lot or adjacent to each accessible space that contains a specific notice that unauthorized vehicles parked in designated accessible spaces will be towed, and includes contact information for retrieving a towed car (24 CCR 1129B.4). Title 24 also contains specific requirements for the “no parking” notice and colors of the paint for accessible parking space striping (*e.g.*, 24 CCR Fig. 11B-18A).
- **International Symbol of Accessibility:** Under the ADA, the ISA can be a light-colored symbol on a dark background, or a dark-colored symbol on a light background (2010 Standards Section 703.7.1). Under Title 24, the ISA must be white on a blue background (24 CCR 1117B.5.8.1.1).
- **Exterior doors:** The ADA does not have a maximum force requirement for exterior doors. Under Title 24, exterior doors cannot require more than 5 pounds of force to push or pull open, unless the door is fire-rated (24CCR 1133B.2.5.3).

- **Door hardware:** The ADA requires door hardware to be mounted 34”-48” AFF (2010 Standards Section 404.2.7). Under Title 24, door hardware must be mounted 30”-44” AFF (24 CCR 1133B.2.5.2).
- **Sales and Service Counters:** Under the ADA, one of each type of sales or service counter must have a portion that is no higher than 36” AFF, and at least 36” long (for a parallel approach) or 30” long with knee/toe clearance (for a forward approach). However, there are two exceptions to these requirements: (1) if the entire counter is less than 36” long, no portion of the counter can be higher than 36” AFF; and (2) in alterations, if providing the required counters would reduce the number of existing counters at work stations, a 24” long counter that is a maximum 36” high is acceptable (2010 Standards Sections 904.4.1 and 904.4.2). Under Title 24, one of each type of sales or service counter must have a portion that is no higher than 34” AFF and at least 36” long.
- **Bed clearance:** The ADA does not contain a requirement regarding clear space underneath accessible beds (although DOJ is working on a new proposed regulation that may contain such a requirement). Title 24 requires clear floor space under an accessible bed (on the long side of the bed) that is at least 7” high to allow space for a bed lift (24 CCR 1111B.4.3).
- **Bathroom Elements:**
 - **Clear floor space at accessible toilets:** The ADA requires the clearance around an accessible toilet to be 60” along the back wall and 56” along the side wall for wall-mounted toilets and 59” for floor-mounted toilets (2010 Standards Section 604.3.1, Fig. 604.8.1.1). Under Title 24, an accessible toilet must also have clearance measuring at least 48” deep in front of the toilet, 60” along the back wall, and 56” (for wall-mounted toilets) or 59” (for floor-mounted toilets) along the side wall (24 CCR 1115B.4.1.2 and 1115B.4.1.2.2).
 - **Centerline for accessible toilets:** Under the ADA, the centerline of an accessible toilet must be 16” to 18” from the side wall or partition (2010 Standards Section 604.2). Under Title 24, the centerline of the toilet must be exactly 18” from the side wall or partition (24 CCR 1115B.4.1.1).
 - **Toilet stall doors:** under the ADA, accessible toilet compartment doors may be located on the front or side wall and must provide a 32” wide clear opening (2010 Standards Section 604.8.1.2). Under Title 24, if the toilet compartment has a side-opening door, it must provide a minimum clear opening width of 34” (24 CCR 1115B.3.1.4.4).

- **Toilet grab bars:** Under the ADA, side-wall grab bars must be mounted 33” to 36” AFF (measured to the top of the gripping surface) (2010 Standards Section 609.4). Title 24 requires side- and rear-wall grab bars to be mounted at 33” AFF (measured to the center of the bar) (24 CCR 1115B.4.1.3.1).
- **Toilet paper dispensers:** Under the ADA, toilet paper dispensers must be located 7”-9” in front of the toilet (measured to the centerline of the dispenser), 15”-48” AFF, and not located behind grab bars (2010 ADA Standards Section 604.7). Under Title 24, toilet paper dispensers must be located on the side wall below the grab bar within 12” of the front edge of the toilet seat, 19”-40” AFF, and no more than 36” from the rear wall (measured to the front of the dispenser) (24 CCR 1115B.8.3 and 1115B.8.4).

XI. RESOURCES

- **Revised Final Title III Rule: A Compilation of Regulatory Provisions and Guidance—Nondiscrimination on the Basis of Disability by Public Accommodations and in Commercial Facilities:** A complete compilation of ADA Title III regulations with 2010 changes fully integrated, plus section by section analysis and regulation preamble:

http://www.ada.gov/regs2010/titleIII_2010/titleIII_2010_regulations.pdf

- **2010 Standards for Accessible Design:**

http://www.ada.gov/2010ADASTandards_index.htm

- **1991 Standards for Accessible Design:**

<http://www.ada.gov/reg3a.html#anchor5757>

- **Revised ADA Requirements: Effective Date and Compliance Date:**

http://www.ada.gov/revised_effective_dates-2010.htm

- **ADA Update: A Primer for Small Business:** An illustrated guide to help small businesses understand the new and updated requirements of the revised ADA regulations:

<http://www.ada.gov/regs2010/smallbusiness/smallbusprimer2010.htm>

- **Service Animals**

http://www.ada.gov/service_animals_2010.htm

- **Pools and spas:**

<http://www.access-board.gov/recreation/guides/pools.htm>

http://www.ada.gov/pools_2010.htm

http://www.ada.gov/ahla_letter_2_21.pdf

http://www.ada.gov/qa_existingpools_titleIII.pdf

http://www.ada.gov/pools_2010.pdf

➤ **Tax Incentives:**

<http://www.ada.gov/taxincent.htm>

- The Department of Justice's ADA Information Line is also available to provide non-binding guidance. The number is 800 - 514 - 0301 (voice), 800 - 514 - 0383 (TTY).

- The American Hotel & Lodging Association provides ADA information at:

<http://www.ahla.com>